



Operating instructions

(Translation of the original operating instructions)

AirTracker



Table of contents

| | |
|--|-----------|
| 1. General | 4 |
| 2. Description of the system elements | 5 |
| 2.1. Illustration of the system elements | 5 |
| 2.2. Functionality of the system | 5 |
| 3. Safety instructions | 6 |
| 3.1. Definition of the hazard symbols | 6 |
| 3.2. General safety instructions | 6 |
| 4. Storage, transport and installation of the device | 7 |
| 5. Commissioning | 8 |
| 5.1. Electrical connection | 8 |
| 5.2. Controlling external devices using the AirTracker | 9 |
| 5.3. Controlling the AirTracker using external end devices | 10 |
| 5.4. Replacing an old AirTracker by a new AirTracker | 10 |
| 5.5. Connecting to the AirTracker's WiFi | 11 |
| 6. Operating the system | 12 |
| 6.1. Explanation of the operating elements | 12 |
| 7. Description of the menu items | 13 |
| 7.1. Home menu | 13 |
| 7.2. Alarm values / limit values menu | 14 |
| 7.3. Dust log menu | 16 |
| 7.4. Settings menu | 18 |
| 8. Maintenance | 27 |
| 8.1. Reset to maintenance state | 27 |
| 8.2. Changing the air quality sensor | 28 |
| 9. Diagnostics and troubleshooting | 29 |
| 10. List of spare parts | 30 |
| 11. Technical data | 31 |
| 12. EC declaration of conformity (according to 2001/95/EC) | 32 |
| 13. Maintenance intervals | 33 |
| 13.1. Usage-related maintenance | 33 |
| 13.2. General maintenance | 33 |
| 13.2.1. Visual inspection of the device | 34 |
| 13.2.2. Electrical test of the electrical lines and earthing connections | 34 |
| 14. Network functions | 35 |
| 14.1. Access to the AirTracker's interface | 35 |
| 14.2. Downloading log data via the AirTracker Access Point | 37 |
| 14.3. Customizing AirTracker Windows settings / external FTP access | 39 |
| 14.4. Integrating the AirTracker into an existing WiFi network (wireless) | 40 |
| 14.4.1. Integrating the AirTracker via DHCP IP address allocation (wireless) | 40 |

| | |
|---|-----------|
| 14.4.2. Integrating the AirTracker using a static IP address (wireless) | 44 |
| 14.5. Integrating the AirTracker into an existing LAN (wired) | 49 |
| 14.5.1. Integrating the AirTracker via DHCP IP address allocation (wired) | 49 |
| 14.5.2. Integrating the AirTracker using a static IP address (wired) | 51 |
| 15. Defining the router's transmission properties | 52 |
| 16. Resetting the AirTracker router | 54 |

1. General

Congratulations on purchasing the product from TEKA.

Our engineers ensure that our devices reflect the state of the art through continuous development. Nevertheless, misuse or misconduct can endanger your safety. Please observe the following for a successful use of the device:



Only authorised and instructed personnel can carry out transport, operation, maintenance and repair of the device. The operator must ensure that the operating personnel take note of these instructions.

Please read these instructions before operating the device, and observe the safety precautions to avoid injury!

Store this manual in a safe place! These instructions are to be regarded as a component of the product!

Adhere to all product notes!

Modifications or conversions that the operator carries out at the device without the consent of the manufacturer, can lead to new safety hazards or to the loss of warranty claims.

Observe the manufacturer's instructions. Contact the manufacturer in case of any uncertainty:

Tel: +49 2541-84841-0

E-mail: info@teka.eu

2. Description of the system elements

2.1. Illustration of the system elements

Installation example:

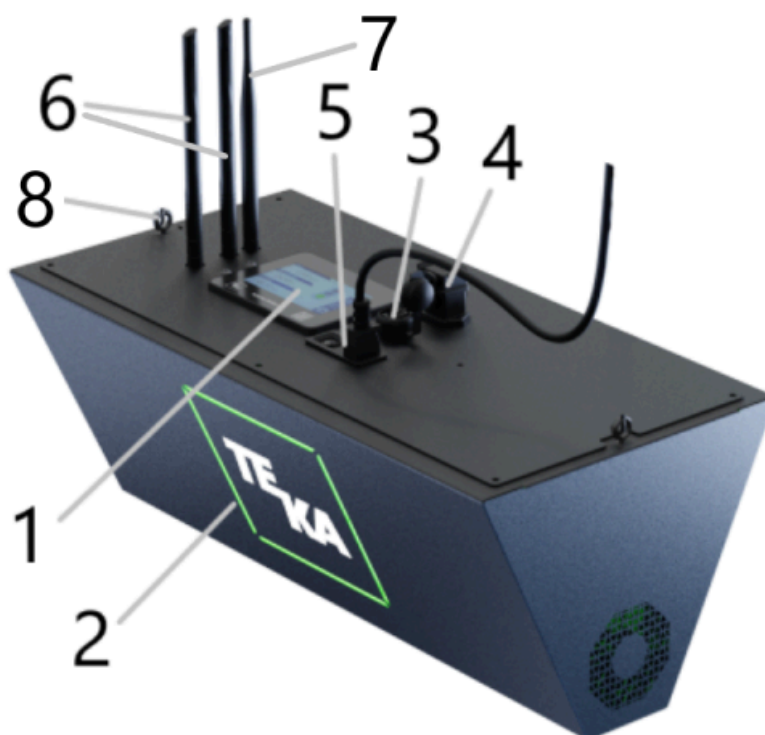

| | | | |
|-------|---|-------|--|
| Pos.1 | Operating panel of the control | Pos.5 | Connection for mains cable, including ON/OFF switch (1.8 metre mains cable included) |
| Pos.2 | LED square ("signal lamp") | Pos.6 | 2 antennas for mobile communications |
| Pos.3 | RJ45 port | Pos.7 | Antenna for WiFi |
| Pos.4 | 8-pin industrial connector (potential-free contact) for transmission of relay signals | Pos.8 | Eye bolts for ceiling suspension |

2.2. Functionality of the system

AirTracker reliably monitors indoor air quality by measuring dust concentration, temperature, and relative humidity. On the basis of these measurements, the air quality is determined and visualised both on the display and by means of different colour indicators on the sides of the device.

The measurements are recorded and can be downloaded from the device as needed. The AirTracker also has potential-free contacts that can be used to control external units. The AirTracker features an integrated router for flexible connectivity.

This means that the AirTracker is network-compatible and can also be viewed and controlled remotely.

3. Safety instructions

3.1. Definition of the hazard symbols

The device is constructed according to the state of the art and the recognised safety regulations. Nevertheless, during use threats to life and limb of the user or other persons may arise. The impairment of the machine or other property are also possible. In these instructions we warn by using corresponding indications.

| | |
|---|--|
|  | WARNING WARNING These instructions are made in case of risks that can lead to <u>injury or death</u> . |
|---|--|

| | |
|---|---|
|  | CAUTION CAUTION These instructions are made in case of risks that can lead to <u>injury</u> . |
|---|---|

| | |
|--|---|
|  | NOTICE NOTICE These instructions are made in case of risks that can lead to <u>material damages</u> . |
|--|---|

| | |
|---|--|
|  | Information notes are no hazard warnings; they call attention to useful information. |
|---|--|

3.2. General safety instructions

| | |
|---|--|
|  | WARNING Dangers arising from improper use / unauthorised operations. The operator must ensure that their authorised personnel are familiar with all the safety indications in this manual in advance. The operator is responsible for ensuring that all work is carried out by authorised and qualified personnel. Laymen are allowed to operate the device after having received the necessary instructions. But they are not allowed to carry out any installation, repair or maintenance work. |
|---|--|

| | |
|---|--|
|  | WARNING Dangers arising from electricity. The operator must ensure that electrical plants and equipment are only built, modified and maintained by a qualified electrician or under the direction and supervision of a qualified electrician. Do not work on components if you are not sure that these are disconnected. If necessary, disconnect the device from the electric power supply and secure it against unauthorized restarting. |
|---|--|

4. Storage, transport and installation of the device

 **WARNING**

Risk of injury arising from the falling unit at its destination.

Ceiling mounting:
The unit must be firmly mounted under the destined ceiling. The ceiling must be vibration-free and horizontal. The operator must check if the ceiling provides a sufficient bearing capacity. Use the 2 eye bolts for fixing the unit (see chapter 2.1.).

Wall mounting:
The unit must be firmly mounted to the destined wall. The wall must be vibration-free and vertical. The operator must check if the wall provides a sufficient bearing capacity. Use the 2 eye bolts for fixing the unit (see chapter 2.1.).

TEKA offers a bracket (item number **2017014032**) as an accessory that is suitable for both ceiling and wall mounting:

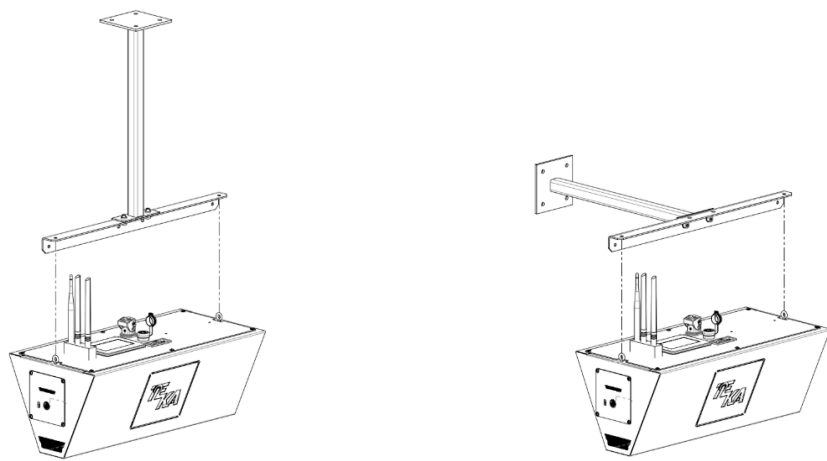

Dangers arising from tilting or functional impairments at its destination.
The unit may be set up alternatively on a suitable surface. The unit may only be set up on a suitable surface. The surface must be vibration-free and horizontal. The operator must check the bearing capacity of the surface. The unit must be secured on the surface.

 **NOTICE**

Damage or functional impairment of the unit due to climatic influences.
The unit must be stored in a dry place and protected against moisture during transport. As a matter of principle, the filter unit is not designed to be installed outside.

Incorrect temperature readings possible.
The unit must be protected from direct sunlight.

- The operator must specify where the AirTracker is to be installed. The position of the AirTracker determines where in the room the air quality is measured. When installing in a metal-processing workshop, we recommend installing at a height of approx. 4 metres.
- When mounting the device in its final position, the WiFi and mobile communications antennas (see chapter 2.1) must be folded out and remain folded out.

5. Commissioning



WARNING

Dangers arising from a defective condition of the unit.

Make sure that the measures described in this chapter are completed before the commissioning of the unit. All required connections must be attached before turning the unit on. Do not operate the unit if any components are defective, missing or damaged. Check the orderly condition of the unit before switching it on.



NOTICE

Damaged supply lines.

Make sure that the supply lines are protected against damage by forklift trucks and similar events. Protect all supply lines from heat, moisture, oil and sharp edges.



We recommend adjusting the set time and date to the local time zone when commissioning the unit. The procedure is described in the chapter "Settings menu / Settings 3".

A correct time and date is important for analysing the data log, for example.

5.1. Electrical connection



NOTICE

Electric malfunction possible in cause of an incorrect power supply.

Pay attention to the admissible supply voltage. Please observe the specifications on the type plate.

- The power supply is provided by the IEC connector. After the cable has been connected, the device can be switched on with the toggle switch.

5.2. Controlling external devices using the AirTracker

| | |
|---|--|
|  | NOTICE |
| | <p>Damage or functional impairment of the unit due to overcurrent. The maximum permissible current carrying capacity is 250 VAC / 6 amps.</p> |

The potential-free relay connections can be used to control other devices or their signalling devices via the AirTracker. The AirTracker therefore offers the possibility to react to critical measurements with automatic “countermeasures”. Possible applications include, for example, switching filter systems, ventilation systems, alarm signalling systems, etc. on or off; the AirTracker is connected via the 8-pin industrial connector on the top of the device (see chapter 2.1).

| | |
|-----------------------|-----------------------------|
| Connection plug type: | Industrial connector |
| Number of pins: | 8 |

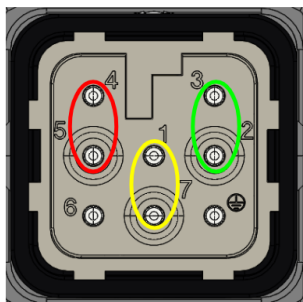
| Pin-Nr. | Explanation |
|--|--|
|  | <p>4 + 5 Potential-free contact: Status red (NO: “normaly open”)</p> |
| | <p>1 + 7 Potential-free contact: Status yellow (NO: “normaly open”)</p> |
| | <p>3 + 2 Potential-free contact: Status green (NO: “normaly open”)</p> |

If you are using a TEKA connection cable with female connector as connection to the relay connections, this cable will be preconfigured with the following wire allocation:

| Wire allocation TEKA connection cable | Explanation |
|--|---|
|  | <p>6 + 5 Potential-free contact: Status red</p> |
| | <p>4 + 3 Potential-free contact: Status yellow</p> |
| | <p>2 + 1 Potential-free contact: Status green</p> |
| <p>Optional accessory: TEKA connection cable for controlling an external system</p> | Article no. |
| AirTracker connection cable 7x 0.75 mm ² , length approx. 50 m | 2017014033 |
| AirTracker connection cable 7x 0.75 mm ² , length approx. 25 m | 201701403325 |

5.3. Controlling the AirTracker using external end devices

Control is possible in a number of ways. These are described in detail in the chapter “Network functions”.

5.4. Replacing an old AirTracker by a new AirTracker

Replacing takes very little effort. If used, disconnect the cable from the 8-pin industrial connector and the network cable from the RJ45 port. The cables used can be connected as they are to the new AirTracker. The connector/wire allocation of the cables and of the 8-pin industrial connector are identical to the AirTracker of the previous generation.

5.5. Connecting to the AirTracker's WiFi



A quick and easy connection of one of your end devices (e.g. PC or laptop) to the AirTracker is possible via the AirTracker's integrated WiFi. If you prefer to integrate the AirTracker into a network, please refer to the chapter "Network functions".



- A 4-digit ID ('XXXX') is indicated on the AirTracker's housing. (Every AirTracker has its own ID.)

ID:XXXX

- Look for the AirTracker in the WiFi settings of your end device. The AirTracker must be switched on for this.
WiFi name (SSID): **TEKA_AirTracker_XXXX**
- Select the AirTracker and enter the password:
WiFi password: **AirTracker24364**
(Some devices require confirmation when connecting to networks without internet access. Check for notifications.)
- Open an internet browser on your end device.
Enter the following address in the address bar:
<http://10.19.95.80:5800>
Password: 24364

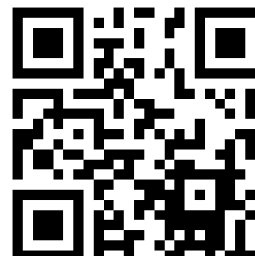

You can also scan the QR-Code instead.
Password: 24364



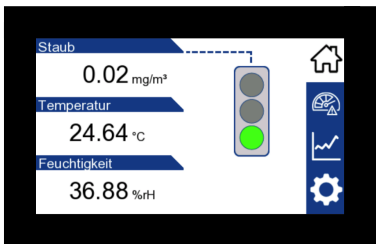

- If you experience any connection problems, refresh the website in your browser or try using a different end device.

6. Operating the system

6.1. Explanation of the operating elements

| Operating elements for the device control | | |
|--|---------------|---|
| Representation | Designation | Description / function |
| <p>Touch display</p>  | | By selecting the icons in the toolbar (right-hand side), you can switch between different menus and display their menu items. The menu items display the values and functions of the system, which can also be changed there. |
|  | ON-OFF-switch | By means of this switch, the device is switched on and off. |

| Operating elements for status and error messages | | |
|---|----------------------------|---|
| Representation | Designation | Description / function |
|  | TEKA logo (white LED) | Lights up to indicate that the unit is being supplied with power. |
|  | Status LED's "signal lamp" | <p>The status LED only lights up when the system is operating and at least one alarm value is enabled; see chapter "alarm values / limit values menu".</p> <p>The status LEDs work in the same way as a signal lamp. The colour indicates whether the currently measured values for air quality are OK. That means:</p> <ul style="list-style-type: none"> green = good yellow = medium red = poor <p> When the device is switched on, the signal lamp lights up red, yellow, green, and blue for 2 seconds each and then changes to the colour corresponding to the air quality.</p> |

7. Description of the menu items

7.1. Home menu

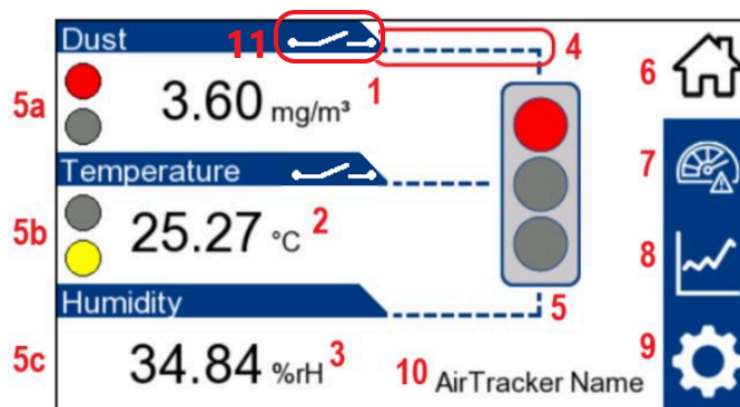

- 1:** Indicates the dust measured (PM2.5 dust particles) in mg/m³
- 2:** Indicates the temperature measured in °C
- 3:** Indicates the relative humidity measured in %rH
- 4:** A dashed line indicates whether this value is enabled and thus included in the assessment of the air quality. If 2 or 3 of the measured values are enabled (can be set in the “Alarm values” menu), the signal lamp shows the worst (colour) value as determined by the limit values (see “Limit values” menu).
- 5:** Depending on the air quality, the signal lamp lights up either green (=good), yellow (=medium), or red (=poor). The signal lamp always shows the worst (colour) value of the enabled values (see **4**). Disabled limit values are not taken into account in the display status. However, critical values of the 3 individual measurement values are displayed in the form of 3 small signal lamps on the home page. In the image above, this means:
 - 5a:** Dust concentration is red (=poor); a red signal lamp lights up,
 - 5b:** The temperature is yellow (=medium); a yellow signal lamp lights up,
 - 5c:** Humidity is good. Therefore, no signal lamp lights up here.> all 3 values are enabled (**4**); in total, air quality is thus red (=poor).
- 6:** The house icon always leads to the home page.
- 7:** The speed indicator icon leads to the alarm and limit value settings.
- 8:** The diagram icon leads to the recorded data.
- 9:** The gear icon leads to the settings.
- 10:** When selecting the name, you can enter a new, custom name showing at which production site the AirTracker is used, for example.
- 11:** A switch symbol indicates that the relay function is active at this value (see menu “Alarm values”).

7.2. Alarm values / limit values menu

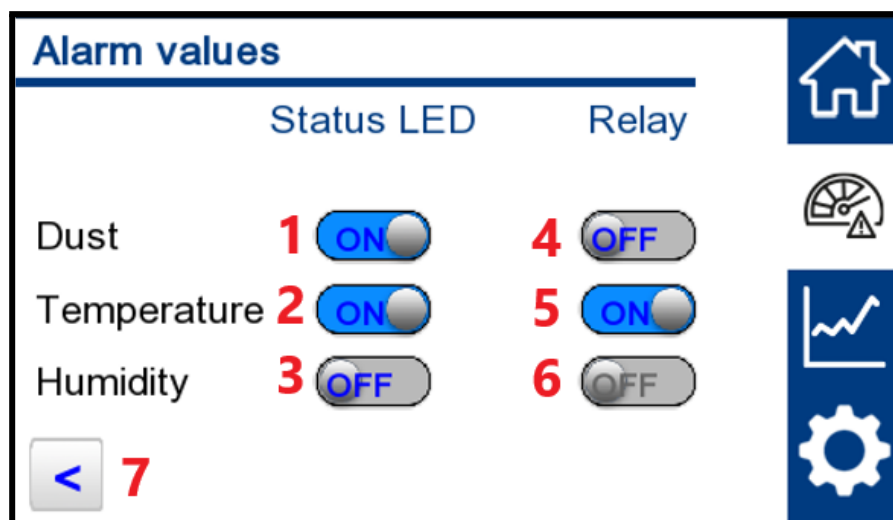

Alarm values

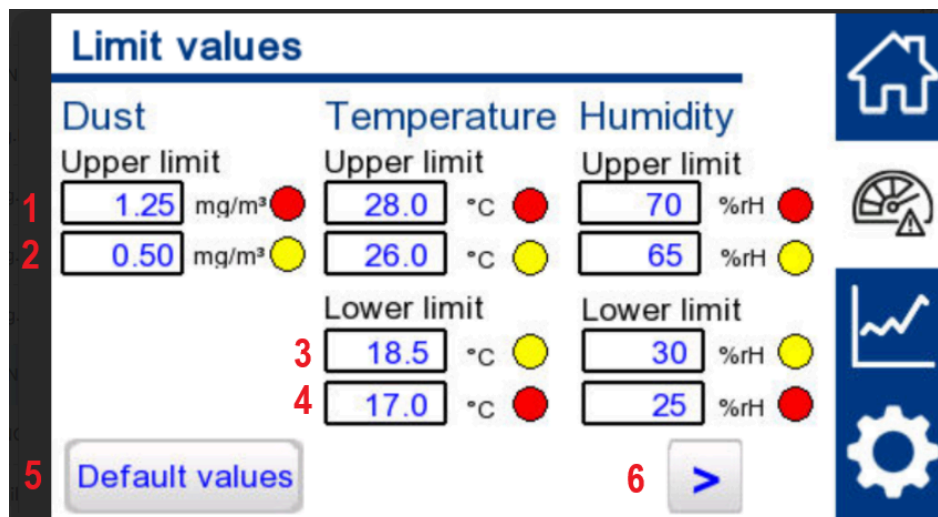

- 1:** Enable / disable whether the measured dust value should be included in the indication of the signal lamp (see “Home” menu).
- 2:** Enable / disable whether the measured temperature value should be included in the indication of the signal lamp (see “Home” menu).
- 3:** Enable / disable whether the measured humidity value should be included in the indication of the signal lamp (see “Home” menu).
- 4, 5, 6:** Under “Relay”, the relay function of the respective measurement (**1, 2, 3**) can be enabled and disabled. As soon as the measurement exceeds or falls short of its limits, the relay outputs switch. If the relay function was enabled with several measurements, the worst value is always the dominant one.
 - i** In the case of Temperature and Humidity, no difference is made whether an upper limit was exceeded or a lower limit was undercut. The corresponding relay output is enabled in both cases.
 - i** To be able to enable the relay function at a certain value
 - a) the value in “Status LED” must also be enabled,
 - b) in the menu “Settings 2” the menu item “Activate relays” must be active.
- 7:** Go to “Limit values”.

Limit values



- 1:** Adjustable upper limits (dust / temperature / humidity) above which the respective signal LED lights up red.
- 2:** Adjustable upper limits (dust / temperature / humidity) above which the respective signal LED lights up yellow. For values lower than this limit, the respective signal LED lights up green (for temperature and humidity until the lower limit is reached).
 Regardless of the set yellow limit, the red limit is always reported first if the conditions for it are met.
- 3:** Adjustable lower limits (temperature / humidity) below which the respective signal LED lights up yellow. For values above this limit, the respective signal LED lights up green until the upper limit is reached.
 Regardless of the set yellow limit, the red limit is always reported first if the conditions for it are met.
- 4:** Adjustable lower limits (temperature / humidity) below which the respective signal LED lights up red.
- 5:** When this button is pressed for 2 seconds, all limit values are reset to the default values (This illustration shows the factory default values).
- 6:** Back to "Alarm values".

7.3. Dust log menu

Dust log

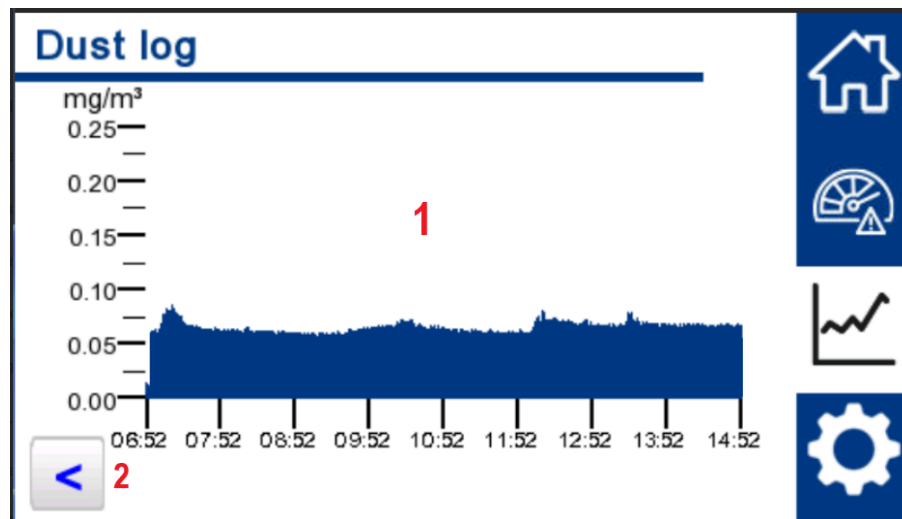

1: The diagram shows the dust concentration as a function of time. The plotted values represent the measurements of the last 8 hours. The height of the Y-axis is based on the upper red limit value for dust, see the “Limit values” menu.

i Graphs for temperature and humidity are not displayed, even if they are enabled in the “Alarm values” menu.

2: Go to “Log table”.

Log table

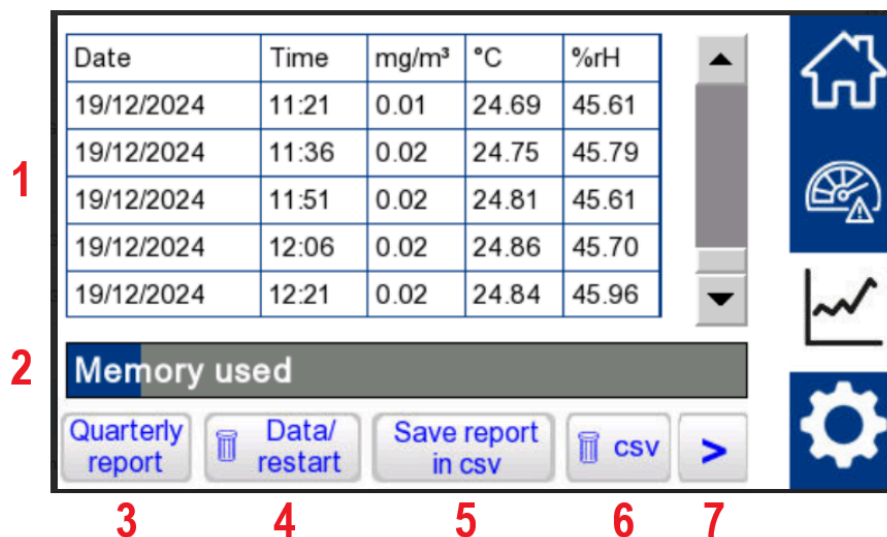





The screenshot shows a user interface for a log table. At the top, a table displays measurement data with columns for Date, Time, mg/m³, °C, and %rH. Below the table is a 'Memory used' bar that fills from left to right. At the bottom, there are five buttons: 'Quarterly report', 'Data/restart', 'Save report in csv', 'csv', and a right arrow. A vertical sidebar on the right contains icons for home, a gauge, a line graph, and settings. Red numbers 1 through 7 are placed around the interface to indicate specific features: 1 points to the table, 2 to the memory bar, 3 to the 'Quarterly report' button, 4 to the 'Data/restart' button, 5 to the 'Save report in csv' button, 6 to the 'csv' button, and 7 to the right arrow button.

| Date | Time | mg/m ³ | °C | %rH |
|------------|-------|-------------------|-------|-------|
| 19/12/2024 | 11:21 | 0.01 | 24.69 | 45.61 |
| 19/12/2024 | 11:36 | 0.02 | 24.75 | 45.79 |
| 19/12/2024 | 11:51 | 0.02 | 24.81 | 45.61 |
| 19/12/2024 | 12:06 | 0.02 | 24.86 | 45.70 |
| 19/12/2024 | 12:21 | 0.02 | 24.84 | 45.96 |

Memory used

Quarterly report Data/restart Save report in csv csv >

- 1:** The table shows each measuring point with the date and time and the last 3 measured values. The measured values are displayed as the average value of the past 15 minutes.
 Initially the table will be displayed empty. Button **3** (Quarterly report) must be selected before the measurement data are read into the table.
- 2:** The bar shows the memory capacity available for measurement data. The bar fills (in blue) from left to right. When the memory is full, a red frame flashes around the bar. Data is collected over a three-month period. Data older than three months are overwritten with more recent data.
 If the memory is full, we recommend to delete the .csv files (**6**). If you wish to keep the data, you can download it to an external device (see chapter 14.2).
- 3:** Pressing the button displays the current measurement data in the table. The data is not updated automatically; the button must be pressed again later.
 Displaying the data can take up to 30 seconds.
- 4:** This button deletes all stored measurement values from the database and restarts the HMI display.
 We recommend to delete the data if the AirTracker is physically used in a different location. Before doing so, consider whether you want to create and download a .csv file (**5**).
- 5:** The button creates a .csv file with measurement values shown in the table.
 A .csv file is used for the long-term documentation of measured values. The .csv file can be downloaded for this purpose (see chapter 14.2.).
- 6:** Pressing this button deletes all .csv files stored on the device.
- 7:** Back to "Dust log".

7.4. Settings menu

Settings 1 (language / software versions)

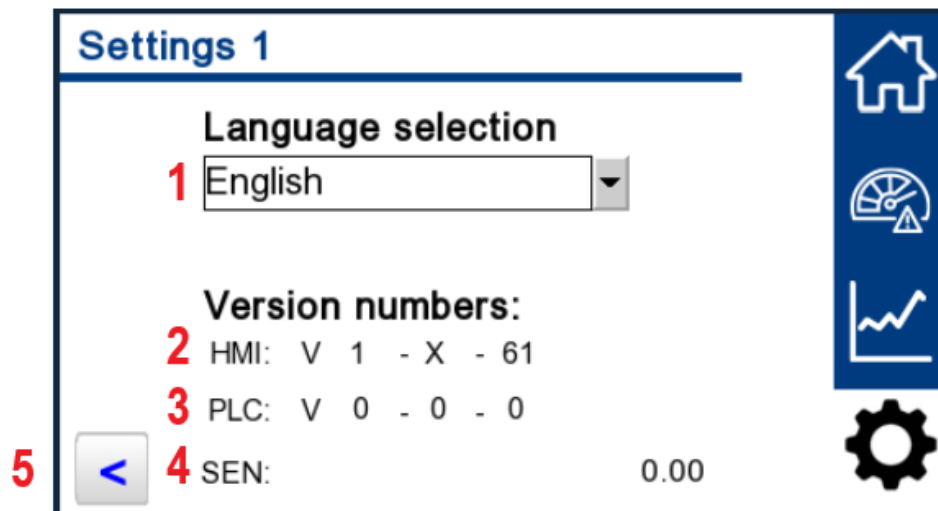

- 1:** Language selection (DE + EN)
- 2:** Shows the HMI software version number.
- 3:** Shows the PLC software version number.
- 4:** Shows the sensor software version number.
- 5:** Go to "Settings 2".

Settings 2 (relay functions)

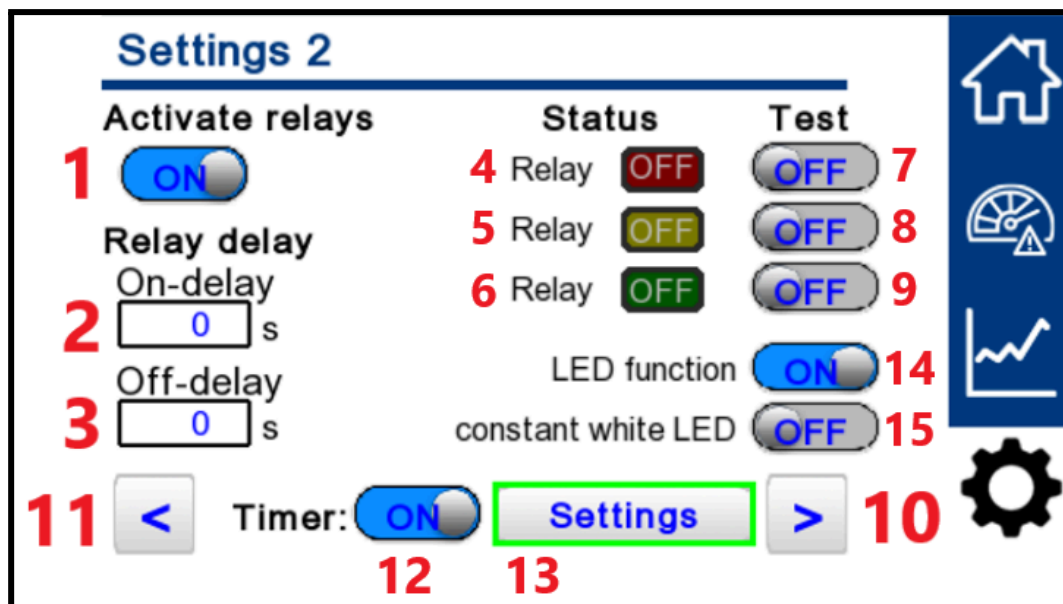

i The status indicating which relay is active (4 red, 5 yellow, 6 green) depends exclusively on the current dust value measured. The temperature and humidity values measured have no significance for the status. This makes sense, since the control of an air filter system has an influence on the dust level in the air, but not on temperature or humidity.

- 1**: Enabling or disabling the relay function. External devices or their signal transmitters can only be controlled when the status is Enabled.
- 2**: Adjustable delay time for a relay to switch on as soon as the measured dust level exceeds the dust limit. The LED display switches immediately, independently of the delay time.
- 3**: Adjustable delay time for a relay to switch off as soon as the measured dust level is below the dust limit again. The LED display switches immediately, independently of the delay time.
- 4, 5, 6**: The status indicates whether one of the relays is enabled. If so, this is indicated by the word "ON" lighting up.
- 7, 8, 9**: Enabling or disabling the "red / yellow / green relays", regardless of the measurement value. This serves as a test instrument for whether or not the relay is used to control an external device or its signal transmitter as desired.

i A test can only be carried out if the relays are enabled (1).

- 10**: Back to "Settings 1".
- 11**: Go to "Settings 3".
- 12**: Enabling or disabling the timer.

13: Continue in submenu “Timer Settings”. If at least one weekday is enabled in the timer, the button “Settings” must have a green border.

 If the button “Activate relays” (1) is disabled, the timer is also disabled and the buttons “Timer” and “Settings” are greyed out and cannot be actuated.

14, 15: Buttons for the “signal lamp”, see chapter 2.1.

14 = ON / 15 = OFF: Depending on the measured values, the signal lamp lights up green, yellow or red.

14 = ON / 15 = ON: Regardless of the measured values, the signal lamp remains constantly white.

14 = OFF / 15 = OFF: The LEDs of the signal lamp do not light up.

Timer Settings

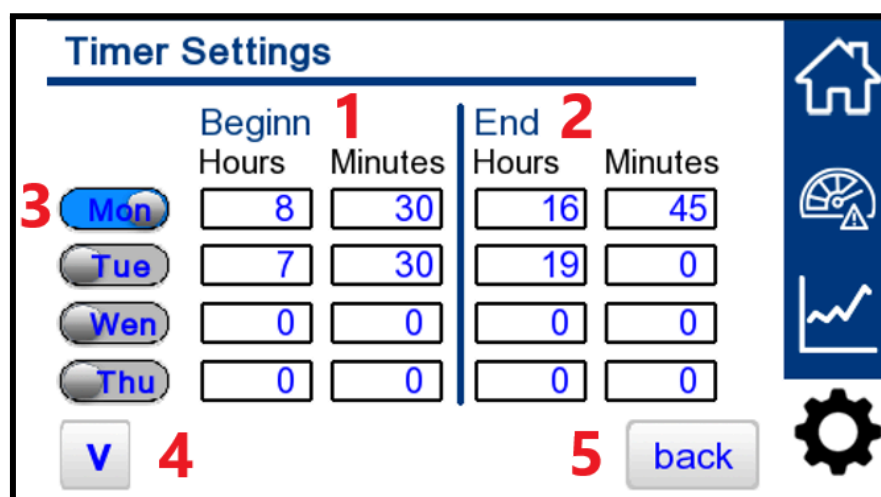

| | Beginn 1 | | End 2 | |
|--------------|-----------------|---------|--------------|---------|
| | Hours | Minutes | Hours | Minutes |
| 3 Mon | 8 | 30 | 16 | 45 |
| Tue | 7 | 30 | 19 | 0 |
| Wen | 0 | 0 | 0 | 0 |
| Thu | 0 | 0 | 0 | 0 |

V **4** **5** back

 The timer refers to the relay functions. The user can set an individual start and stop time for each day. Within this time frame, the relay function is enabled, outside the time frame the relay function is disabled.

1, 2: On the left, the start time of the respective weekday can be set in the 24-hour format. On the right, the end time of the respective weekday can be set in the 24-hour format.

 The relay function can only become active if the end time exceeds the start time. If the start time equals the end time, the relay function is enabled for the entire weekday.

3: The buttons can be used to enable or disable the respective weekday (here: Monday).

4: Continue to the settings for Friday to Sunday.

5: Back to “Settings 2”.

Settings 3 (time and date)

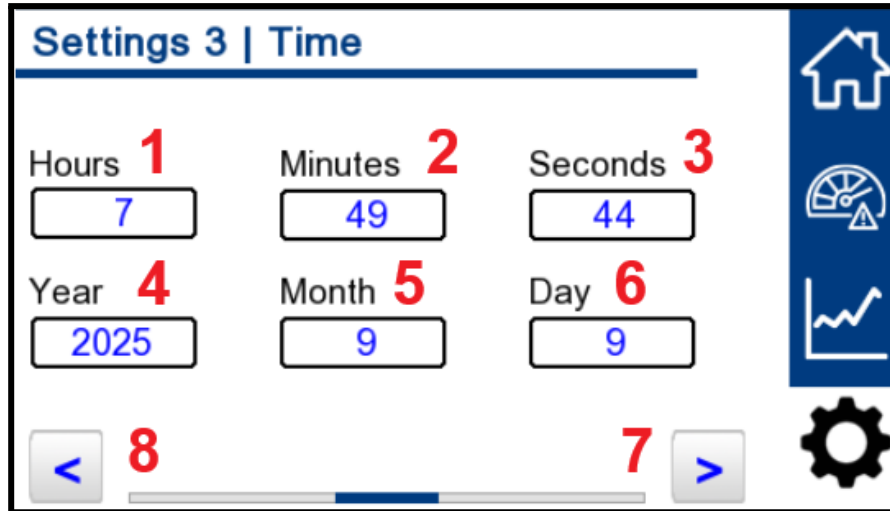

Settings 3 | Time

| | | |
|-----------------------------------|---------------------------------|---------------------------------|
| Hours 1 | Minutes 2 | Seconds 3 |
| <input type="text" value="7"/> | <input type="text" value="49"/> | <input type="text" value="44"/> |
| Year 4 | Month 5 | Day 6 |
| <input type="text" value="2025"/> | <input type="text" value="9"/> | <input type="text" value="9"/> |

8 **7** 

1, 2, 3: Adjustable time: hours, minutes and seconds.

4, 5, 6: Adjustable date: year, month, day.

7: Back to “Settings 2”.

8: Go to “Settings 4”.

Settings 4 (network)

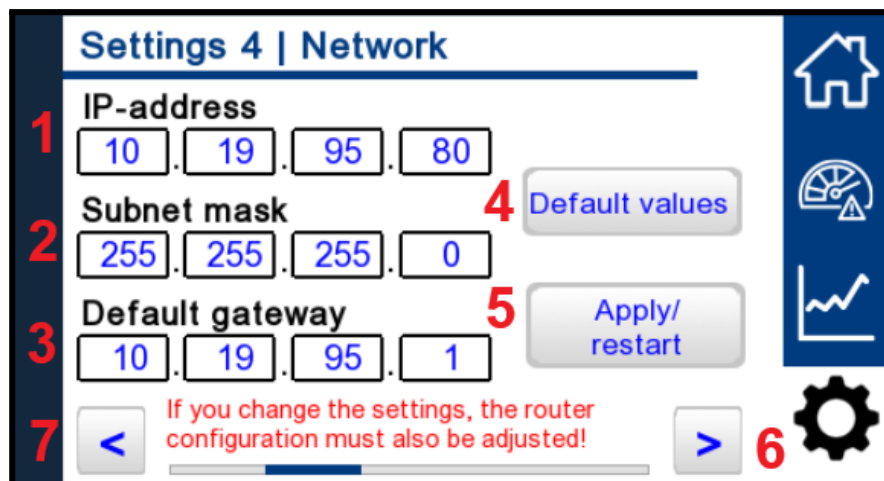

 Changes made in this menu only affect the HMI of the AirTracker. If you wish to adjust the AirTracker's IP address in your network, please read chapter 14.4 or 14.5 of these instructions.

- 1, 2, 3:** Adjustable IP address (the default value is shown).
Adjustable subnet mask (the default value is shown).
Adjustable default gateway (the default value is shown).

 After a setting has been changed, it must be confirmed by pressing button **5**.

4: When this button is pressed for 2 seconds, the IP address (**1**), subnet mask (**2**), and default gateway (**3**) are reset to their default values.

5: If a change has been made to the IP address (**1**), the subnet mask (**2**) or the default gateway (**3**), then the change must be accepted by pressing button **5** for 2 seconds. The HMI display is restarted.

 The PLC software continues to run in the background, thus preventing the relay outputs from changing their switching state as a result of the restart.

6: Back to "Settings 3".

7: Go to "Settings 5".

Settings 5 (MQTT)

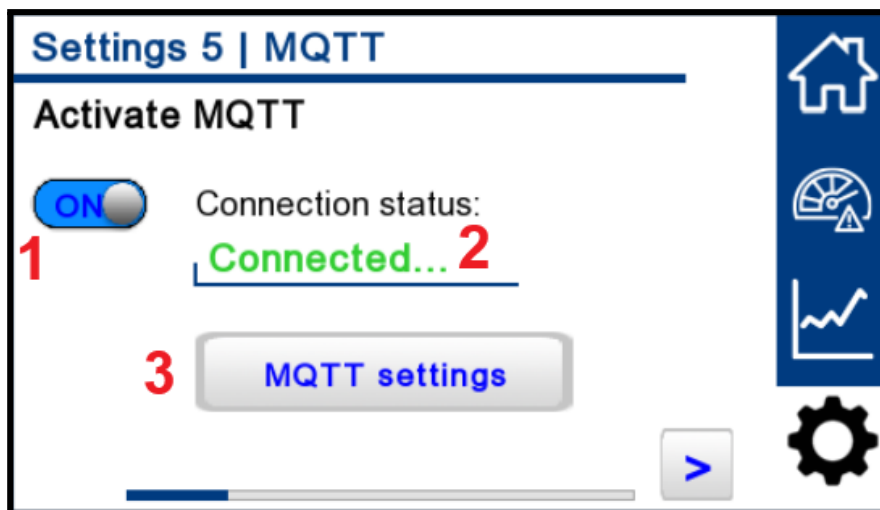

i To use the MQTT function, the MQTT broker must be in the same subnet as the HMI, e.g. in the same company-internal network. Please refer to the information in the chapter “Network functions”. It is not intended to send data to an MQTT broker on the Internet as no TLS encryption is used for this process.

i MQTT data are sent every second.

i Establishing a connection can take up to one minute. During this time, the connection status “**Disconnected...**” is displayed.

1: MQTT is switched “ON” or “OFF”.

2: Display of the connection status.

Stopped... > MQTT is switched off or was stopped.

Disconnected... > The connection is interrupted.

Every 60 seconds, an attempt is made to establish a new connection.

Connected... > A connection has been established, measurements are sent to the broker.

3: Continue in the submenus “MQTT settings”.

i As changes to the MQTT settings are partly only adopted when a new connection to the broker is established, it is recommended to adapt settings when the MQTT is switched off.

4: Back to “Settings 4”.

MQTT settings (server settings)

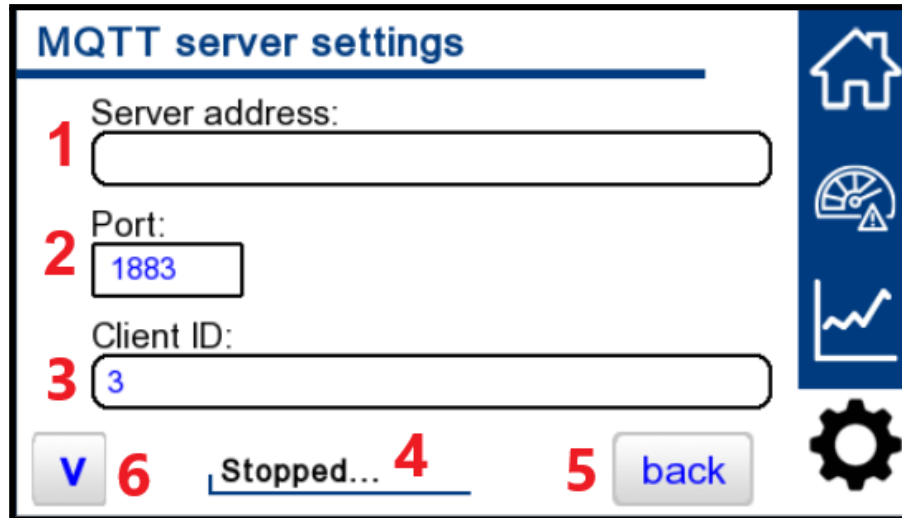

- 1:** The address of the MQTT broker must be entered here, e.g. the IP address.
- 2:** The same port as for the broker must be used. The preset port corresponds to the default MQTT port. In most cases, it can be retained.
- 3:** A client ID must be entered here. With this ID, the AirTracker logs on at the MQTT broker.
 If several AirTrackers are used, each device must be allocated its own ID.
- 4:** Display of the MQTT connection status as described in “Settings 5”.
- 5:** Back to “Settings 5”.
- 6:** Change within the submenus of the MQTT settings.

MQTT settings (user authentication)

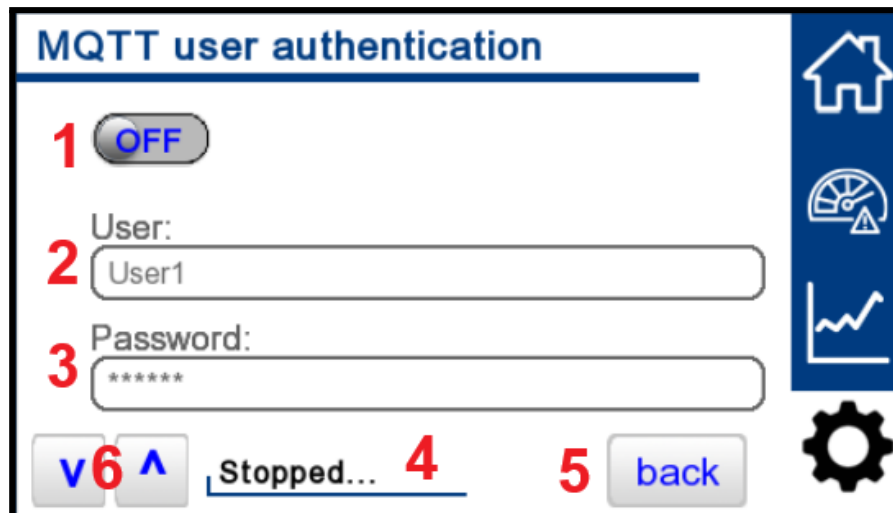

An MQTT broker can be secured with a user authentication. Contact your IT department if anything is unclear.

1: If the broker is equipped with a user authentication, this can be activated here. Subsequently, the corresponding access data for the broker must be specified.



If the broker has no user authentication and an attempt is made to register a user, the broker may refuse to accept the connection.

2, 3: Input fields for the user name and the password. An input is only possible when the user authentication is activated (**1**).

4: Display of the MQTT connection status as described in “Settings 5”.

5: Back to “Settings 5”.

6: Change within the submenus of the MQTT settings.

MQTT settings (message overview)

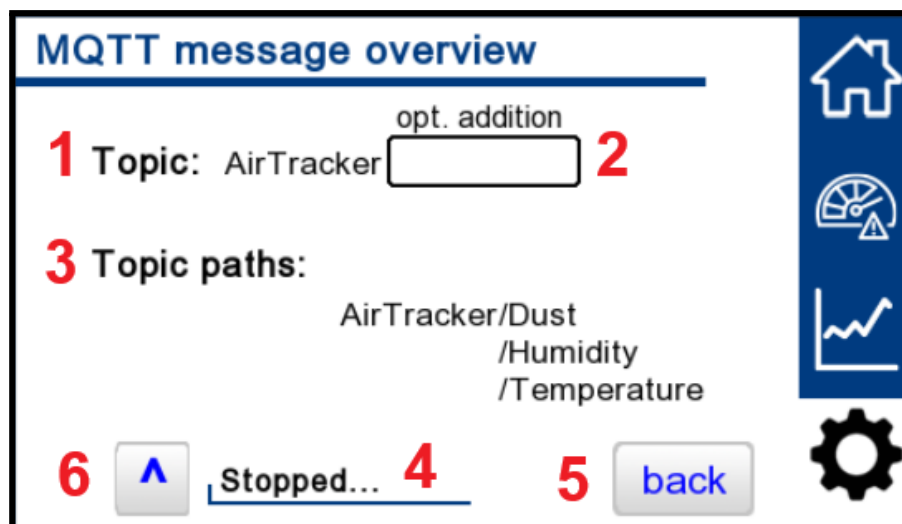

- 1, 2:** Under the topic / designation “AirTracker”, the data are sent from the AirTracker to the MQTT broker. If the optional addendum (**2**) is used, a correspondingly longer topic appears at the MQTT broker.

 The use of the optional addendum is in particular recommended when several AirTrackers are used to be able to distinguish them on the basis of different topics. The addendum can have a maximum length of 8 characters.

- 3:** Display of the topic paths that are sent to the MQTT broker.
The subpaths (subtopics) corresponding to the different measurements are also listed. For example:

| Topic = “AirTracker-Laser-1” | | | |
|------------------------------|-----------|-------------------|--------|
| suptopic = | Data type | Measurement unit | Values |
| Dust | float | mg/m ³ | 0.05 |
| Humidity | float | % | 53.41 |
| Temperature | float | °C | 24.38 |

- 4:** Display of the MQTT connection status as described in “Settings 5”.
- 5:** Back to “Settings 5”.
- 6:** Change within the submenus of the MQTT settings.

8. Maintenance

In accordance with national regulations, the operator is obliged to carry out repeat and functional tests. Unless otherwise specified by national regulations, we recommend regular visual inspections and functional tests of the device as described in the chapter “Maintenance intervals”.



You find the chapter “Maintenance intervals” at the end of the document. The general maintenance (visual inspection, etc.) is also explained there.



WARNING

Work on the open system entails the risk of electrical shock.

There is no maintenance work that requires opening the housing of the AirTracker. Opening is not permitted. For this purpose, the housing is also sealed. Damage to a seal will void the product warranty.

Dangers to life and limb when non-original spare parts are used

Only original TEKA spare parts must be used.

8.1. Reset to maintenance state

- Switch off the unit. Unplug the mains plug. Secure the unit against unauthorized restarting during maintenance.
- After completion of all maintenance work the unit can be reconnected to the power supply.

8.2. Changing the air quality sensor

The air quality sensor monitors the ambient air for measurement purposes. Contaminations in the air can lead to failure of the air quality sensor in the long term. To prevent failures, we recommend to change the air quality sensor (see spare parts list) at regular intervals.

The change interval depends on the accumulating dust quantity and can therefore not be determined beforehand. In one-shift operation we recommend to change the air quality sensor once a year.

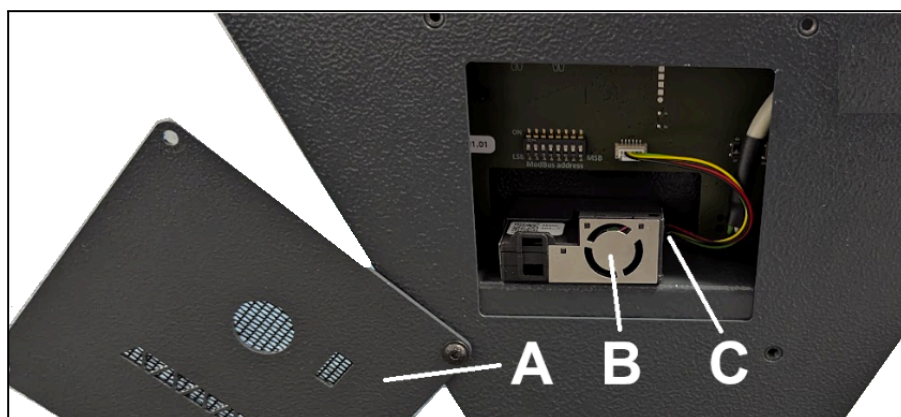

- Loosen the screw connections of the cover plate (A). Check the cover plate and its protective grille for damage. In case of doubt, also replace the cover plate (see spare parts list).
- Carefully pull the sensor (B) out of the housing.
- Unfasten the cable (C) by carefully pulling on the sensor.
- Insert the cable into the new sensor.
- Carefully slide the new sensor in position.
- Screw the cover plate in place.
- As soon as the device has been put back into operation, check whether the air quality sensor functions properly. To do so, check whether changing measurements are shown on the display.

 After the device is switched on, it takes approx. 3 minutes for reliable measurement values to be displayed.

9. Diagnostics and troubleshooting

A list of possible system errors is provided in the table.

 Faults indicated by control elements are explained in the chapter "Description of the control elements".

A recommissioning of the device must only occur if it is ensured that the system is functionally equivalent to the original state. Repairs may only be carried out by TEKA personnel or, after consultation with TEKA, by the personnel authorised by the operator.

Adhere to the instructions in the chapter "Safety instructions" and "Maintenance" when carrying out any repairs. If in doubt, contact our TEKA service department:

Tel: +49 2541-84841-0
E-mail: info@teka.eu

| Fault | Cause | Removal |
|--|--|---|
| LED square alternates between BLUE and RED | Internal power supply is interrupted. | <ul style="list-style-type: none"> - Restart the device by switching the power supply off and on. - To temporarily stop the light from flashing, you can disable all values in the "Alarm values" menu. - If the problem persists, contact TEKA Service. |
| LED square does not light up | All alarm values are disabled | Enable the desired values in the "Alarm values" menu. Note: After the AirTracker was turned on, it carries out a light test. |
| LED square lights up differently on one side | Internal error | Please contact the TEKA service department |
| TEKA icon does not light up | No power supply available | Check whether the unit is switched on (chapter 6.1) |
| Implausible / permanently consistent measurement values | The device has just been switched on. | It takes approx. 3 minutes for reliable measurement values to be displayed. |
| | Sensor may be defective. | Replace the air quality sensor. |
| Access to AirTracker interface via Access Point does not work / website not loading. | Network connection not yet properly established. | Some devices require confirmation when connecting to networks without internet access. Check notifications and confirm the connection. |
| When accessing the AirTracker interface, the image is just grey. | Website must be reloaded the first time it is connected. | Refresh the website (several times if necessary) until you are prompted to enter the password. |

| Fault | Cause | Removal |
|---|--|---|
| Accessing the FTP server takes very long or causes an error message | Incorrect end device setting for "passive FTP" | Depending on the connection method used with the AirTracker, enable or disable "passive FTP" (see chapter 14.3) |
| Impossible to access the AirTracker via network connection | Restart required | Restart the device by switching the power supply off and on. It may take up to 5 minutes for the network connection to be re-established. |
| | Incorrect or modified network configuration | <ul style="list-style-type: none"> - Reset the configuration to the TEKA presets (User's default configuration) See chapter "Resetting the AirTracker router" - Check the network configuration according to the steps in chapter "Network functions" |

10. List of spare parts

| | |
|---|----------------|
|  | WARNING |
| Dangers to life and limb when non-original spare parts are used. Only original TEKA spare parts must be used. | |

| Other parts | Article no. |
|--|-------------|
| Air quality sensor | 2017014001 |
| Mains cable 1,8m | 2017014003 |
| Cover plate with protective grille, for air quality sensor | 2017014004 |
| Antenna for mobile communications | 2017014005 |
| Antenna for WiFi | 2017014006 |

11. Technical data

| | | |
|-----------------------------|-------|---|
| Supply voltage | V | 100 - 240 |
| Current intake | A | 1,8 |
| Frequency | Hz | 50 / 60 |
| Type of current | Ph | 1 |
| Protection class | | IP20 |
| Width | mm | 580 |
| Depth | mm | 290 |
| Height | mm | 430 |
| Weight | kg | 12 |
| Sound pressure level | dB(A) | 20 |
| Allowed ambient temperature | °C | +5 to +35 (<i>during operations</i>) -10 to +40 (<i>during transport and storage</i>) |
| Allowed humidity | % | 20 to 90 (<i>during operations, non-condensing</i>) 10 to 80 (<i>during transport and storage, non-condensing</i>) |

12. EC declaration of conformity (according to 2001/95/EC)

TEKA Absaug- und Entsorgungstechnologie GmbH

Millenkamp 9, D-48653 Coesfeld

Tel.: +49 2541-84841-0

E-Mail: info@teka.eu

Internet: www.teka.eu

Designation of the device: AirTracker

We declare under our sole responsibility that the following guidelines have been applied for the above mentioned product:

Electromagnetic Compatibility: 2014/30/EC

Low Voltage Directive: 2014/35/EU

RoHS directive: 2011/65/EU

This declaration will become void if the device is exposed to modifications that are not approved by the manufacturer in written form.

Authorized representative for the technical documentation:

TEKA Absaug- und Entsorgungstechnologie GmbH, Millenkamp 9, D-48653 Coesfeld

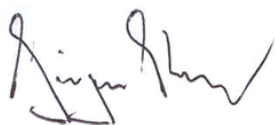

(Jürgen Kemper, managing director)

Coesfeld, 3rd January 2025

13. Maintenance intervals

13.1. Usage-related maintenance

The described maintenances become necessary through the demands of the system operations. The maintenance intervals are recommendations. Depending on the application (multi-shift operation, dust generation, ...) it may make sense for the operator to change the intervals of maintenance, replacing and cleaning.

Maintenance work must always be documented by means of a protocol.

The approach of the maintenance measures is described in chapter "Maintenance".

| Maintenance work | Chapter | Maintenance interval | |
|---------------------------------|---------|--|----------------------------|
| | | recommended by TEKA | determined by the operator |
| Changing the air quality sensor | 8.2. | annually (in case of one-shift operation) | |

13.2. General maintenance

The described maintenances are independent from the demands of the system operations.

The operator is obliged to carry out repeated inspections and functional tests according to national regulations. If not otherwise covered by national regulations, the described maintenance intervals must be respected.

Maintenance work must always be documented by means of a protocol.

| Maintenance work | Chapter | Maintenance interval |
|---|---------|----------------------|
| Visual inspection of the device | 13.2.1. | weekly |
| Electrical test of the electrical lines and earthing connections | 13.2.2. | annually |

13.2.1. Visual inspection of the device

Visual inspection: Observation that there are no visible safety-related defects.

| | |
|--|----------------|
|  | WARNING |
| Danger arising from the ready to operate condition of the device. Follow the procedure as described in the chapter "Set to maintenance state". | |

The following steps must be carried out in the course of the visual inspection:

- Ensure that all parts are firmly connected.
- Visual inspection of the control and operating elements as well as the outside running cables for damages.

13.2.2. Electrical test of the electrical lines and earthing connections

| | |
|--|----------------|
|  | WARNING |
| Danger arising from electricity. The operator is responsible for ensuring that all work on electric components is carried out by authorised and qualified personnel. | |

The device is subject to regular electrical checks by the operator of the device, and are subject to national standards of the different countries.

The here recommended maintenance interval complies with the in Germany applying "Regulation 3 of the German Social Accident Insurance - Electrical plants and equipment" (formerly known as BGV-A3).

The check must only be carried out by a qualified electrician or a person trained in electrics using suitable measuring and test devices. The scope of testing and the methods must be in line with the respective national standard. All contacts in the control cabinet must be checked for tight fit, and must be readjusted if necessary.

14. Network functions



This chapter explains the basic connection types as well as the advanced network functions. The AirTracker features an integrated router for flexible connectivity. Certain network functions require changes in the router's interface settings.

14.1. Access to the AirTracker's interface

Access is possible from one of your end devices (e.g. PC or laptop) via Ethernet, the AirTracker Access Point or an existing network.

Option 1 - AirTracker Access Point:

- The IP settings for your end device can be set to automatic (DHCP), which is the standard for most end devices, especially mobile devices.
- Connect your end device to the AirTracker's WiFi. The WiFi name (SSID) is TEKA_AirTracker_XXXX with the 4-digit ending being different for each AirTracker. The WiFi password is: **AirTracker24364**
- Enter the following URL in the browser of your end device:
10.19.95.80:5800 (default setting)
- A confirmation prompt appears. The password is: **24364**
Then the user interface of your AirTracker appears in the browser.

Option 2 - Ethernet:

- Connect your end device to the AirTracker using an Ethernet cable. Connect the Ethernet cable to the RJ45 port on the top of the device (see chapter 2.1.).
- In the network settings of your end device, set the IP address to the IP address range of the AirTracker.
 - Default IP of the AirTracker: **10.19.95.80**
 - Default IP of the router: **10.19.95.1**
 - Default subnet mask: **255.255.255.0**
- Enter the following address in the browser of your end device: **10.19.95.80:5800**
- A confirmation prompt appears. The password is: **24364**
Then the user interface of your AirTracker appears in the browser.

Option 3 - Existing network:

- Integrate the AirTracker into an existing network. Please note the information in the chapter “Integrating the AirTracker into an existing network via Ethernet”.
- Enter the IP address assigned by your network in the browser of your end device and append the network as follows: **XXX.XXX.XXX.XXX:5800**
- A confirmation prompt appears. The password is: **24364**
Then the user interface of the AirTracker appears in the browser

14.2. Downloading log data via the AirTracker Access Point

Establishing a connection and saving data:

- Establish a connection to the AirTracker network. To do so, search for the network of the desired AirTracker on a suitable end device.



If necessary, enter the network password to establish the connection.

Establish FTP access:

- Open the Windows Explorer.
Click on the file path and replace the current path by:
ftp://10.19.95.80 (default setting of the HMI IP address).

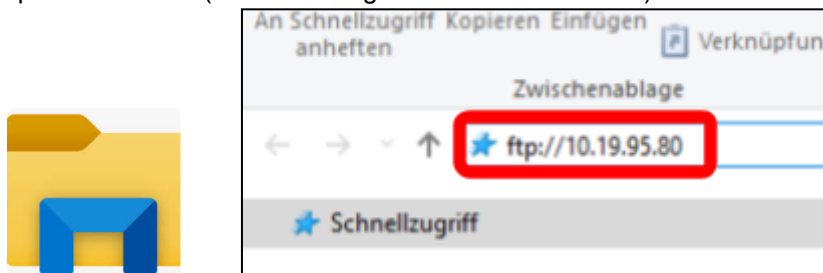

- Enter the user name "root" and the password "24364" in the following user prompt.

| | |
|---------------|-------------|
| FTP-Server: | 10.19.95.80 |
| Benutzername: | root |
| Kennwort: | 24364 |

- After login, two windows will open. One of them shows the folder "hmi". In the "hmi" folder, there is a subfolder "export" with the subfolder "CSV_Datalog". The latter contains the log files in .csv format. Copy the files from the folder to your end device.



Please note! The files must be copied to your end device before they can be opened. This is not possible if they are only stored on the AirTracker.

The Air Cleaners

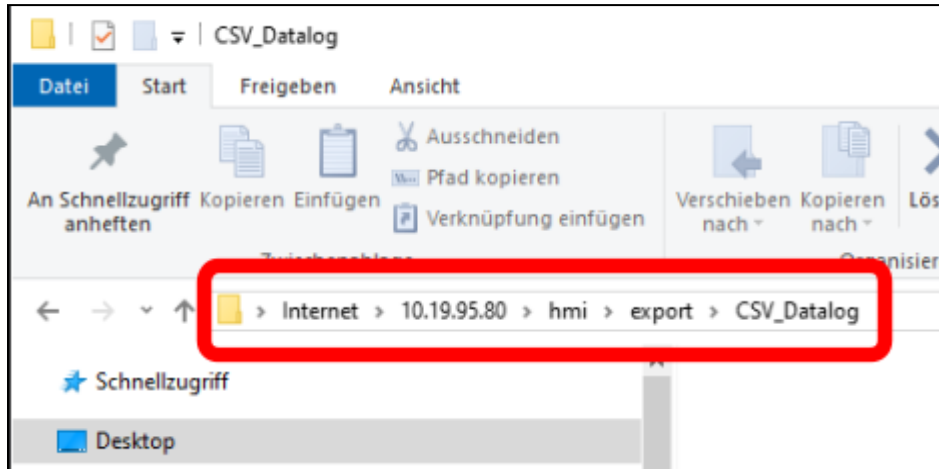

Example of a .csv file:

| Datei | Bearbeiten | Format | Ansicht | Hilfe |
|------------|------------|--------|---------|-------|
| Date | Time | Dust | Temp | RH |
| 2024-08-19 | 07:05 | 7.3 | 21.58 | 55.45 |
| 2024-08-19 | 07:06 | 7.7 | 21.55 | 55.42 |
| 2024-08-19 | 07:07 | 8.0 | 21.52 | 55.22 |
| 2024-08-19 | 07:08 | 7.4 | 21.47 | 55.14 |
| 2024-08-19 | 07:09 | 7.6 | 21.43 | 55.28 |
| 2024-08-19 | 07:10 | 8.0 | 21.39 | 55.39 |
| 2024-08-19 | 07:11 | 7.4 | 21.36 | 55.72 |

14.3. Customizing AirTracker Windows settings / external FTP access

Preface:

The simplest way to download the *.csv files from the AirTracker is directly from the (wireless)LAN created by the AirTracker. If the AirTracker is integrated in an external network, such as an existing WiFi network, a setting has to be adjusted for FTP access; otherwise, an error message similar to the following may appear:



This chapter describes the settings required in Windows to enable access.

Customizing settings:

- Open the Windows internet options on your end device.
(Start / Search > Control panel > Search control panel > enter “internet options” and open).
- Select the “Extended” tab. In “Browse” **disable** the setting “Use passive FTP”. Confirm the change with “OK”.

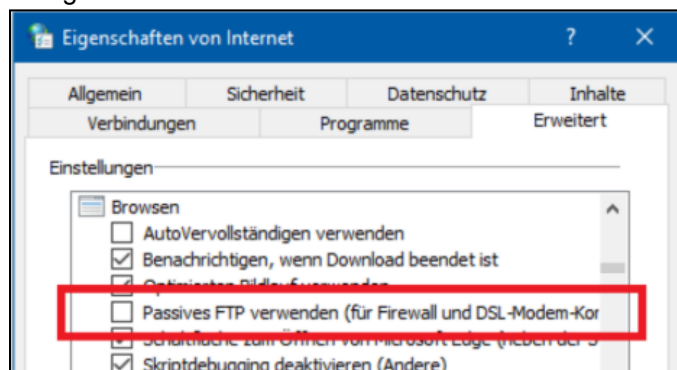

- After changing the setting, restart your end device.
You can now access the FTP server of the AirTracker via Windows Explorer.

14.4. Integrating the AirTracker into an existing WiFi network (wireless)

This section describes the wireless integration of the AirTracker into an existing network.

14.4.1. Integrating the AirTracker via DHCP IP address allocation (wireless)



IMPORTANT : When using this connection type with the AirTracker, the IP address settings **must** be set to the default values, see chapter 7.4. “Settings menu → Settings 4”.

Connecting to the integrated router of the AirTracker:

- Connect your end device to the RJ45 port (see chapter 2.1) of the AirTracker (see chapter 14.1).
- The LAN port of the AirTracker’s router has the following IP address by default: **10.19.95.1**
Temporarily set your end device to the same address range to have access to the router of the AirTracker.
- The following IP address can then be accessed in the browser: **10.19.95.1**

Logging on to the integrated router of the AirTracker:

- The login page for the router opens in the browser. Enter the following credentials:
Username: **user** / Password: **Router24364**

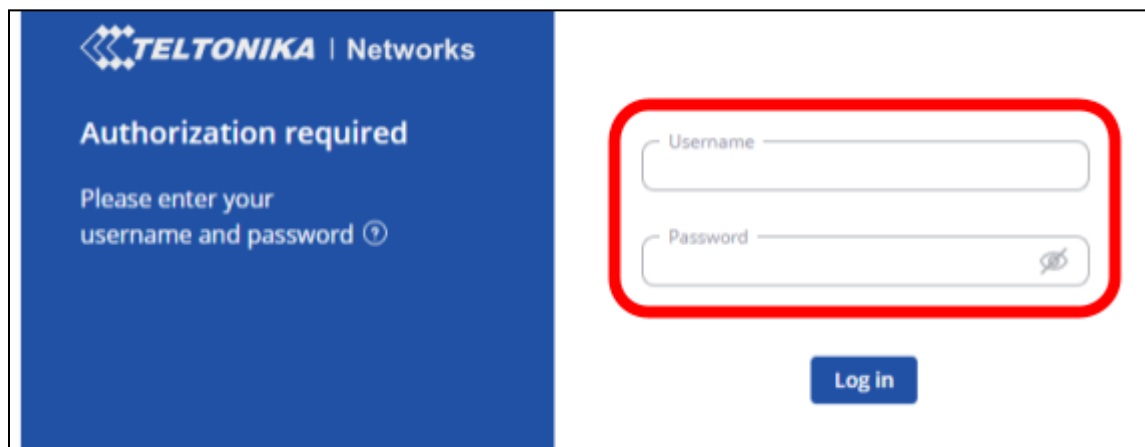

TELTONIKA | Networks

Authorization required

Please enter your username and password ⓘ

Username

Password ⓘ

Log in

- After logging in, go to “Network → Wireless”. In this menu, you can search for the existing WiFi network. To do this, press the “Scan 2.4 GHz” button.

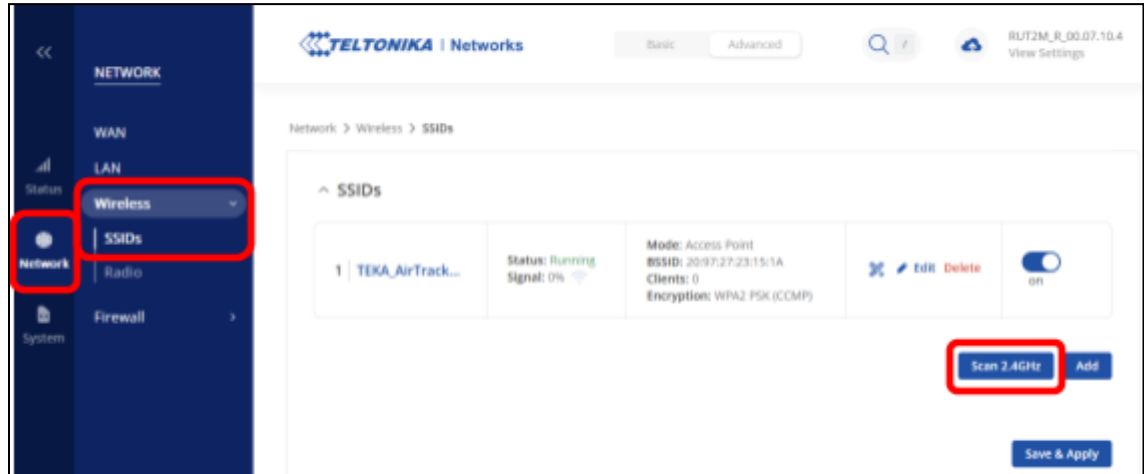

- A list of accessible WiFi networks will open. Select the desired network. Confirm the selection with “join network”. Then enter the WPA key of the target network and confirm it.



You can only connect to one additional external WiFi network; otherwise, an error message appears when you try to add the network.

- A menu window will open with settings for the target network. Check the desired settings in the “General Setup” tab.

- In the “Additional Settings”, enable the function “Enable fast roaming: ON”. After enabling the function, an additional tab “Fast Roaming” will appear. The basic settings can be used here.

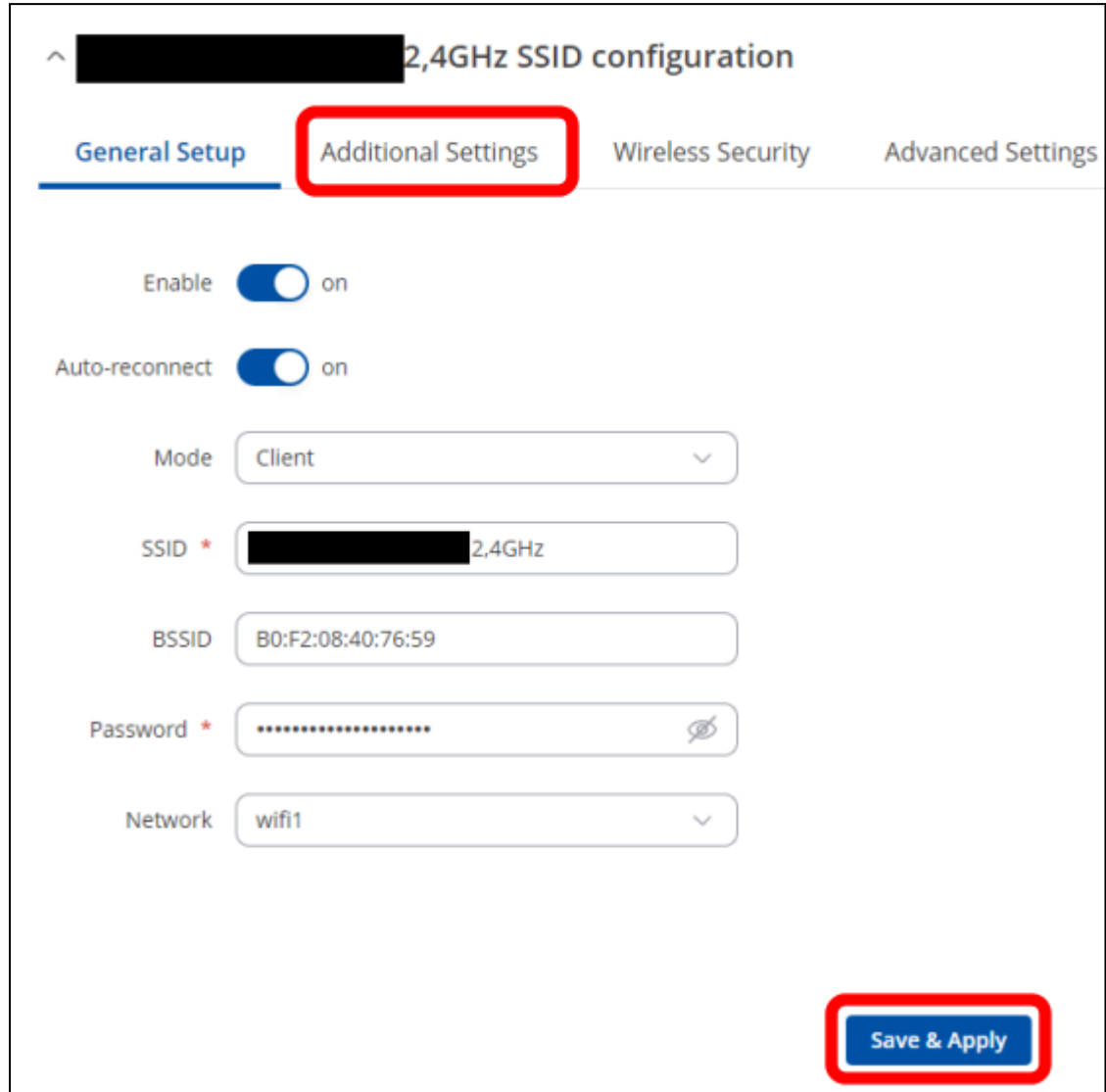

^ [redacted] 2,4GHz SSID configuration

General Setup **Additional Settings** Wireless Security Advanced Settings

Enable on

Auto-reconnect on

Mode Client

SSID * [redacted] 2,4GHz

BSSID B0:F2:08:40:76:59

Password *

Network wifi1

Save & Apply

- Then you can confirm with “Save & Apply”.

- After that, the settings for “wifi1” will open.

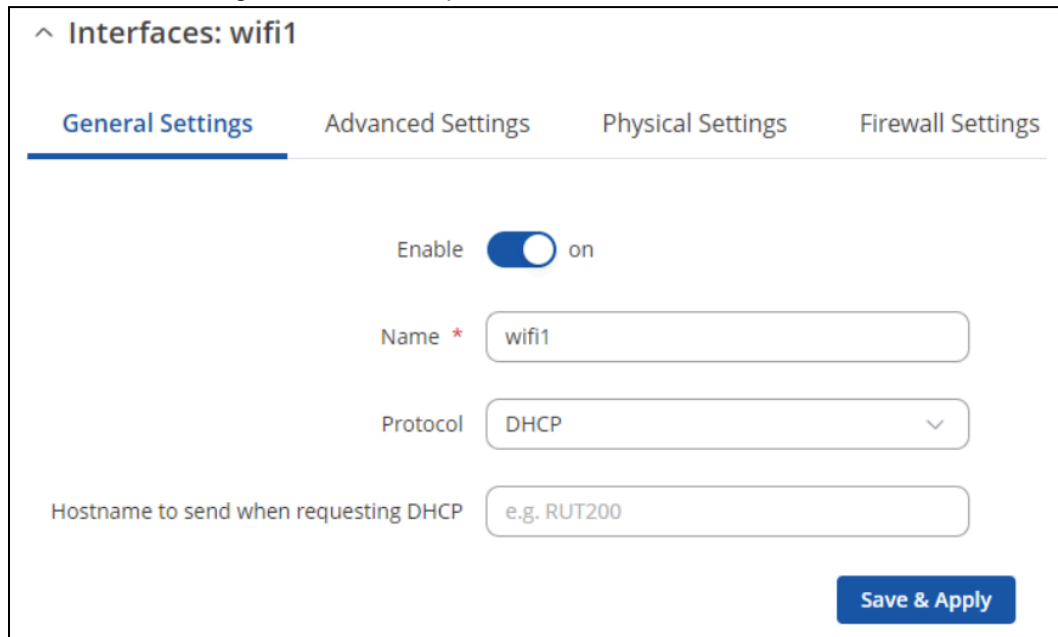

^ Interfaces: wifi1

General Settings Advanced Settings Physical Settings Firewall Settings

Enable on

Name *

Protocol

Hostname to send when requesting DHCP

Save & Apply

- Here, under the “Firewall Settings” tab, the firewall zone “WirelessWAN” must be selected.

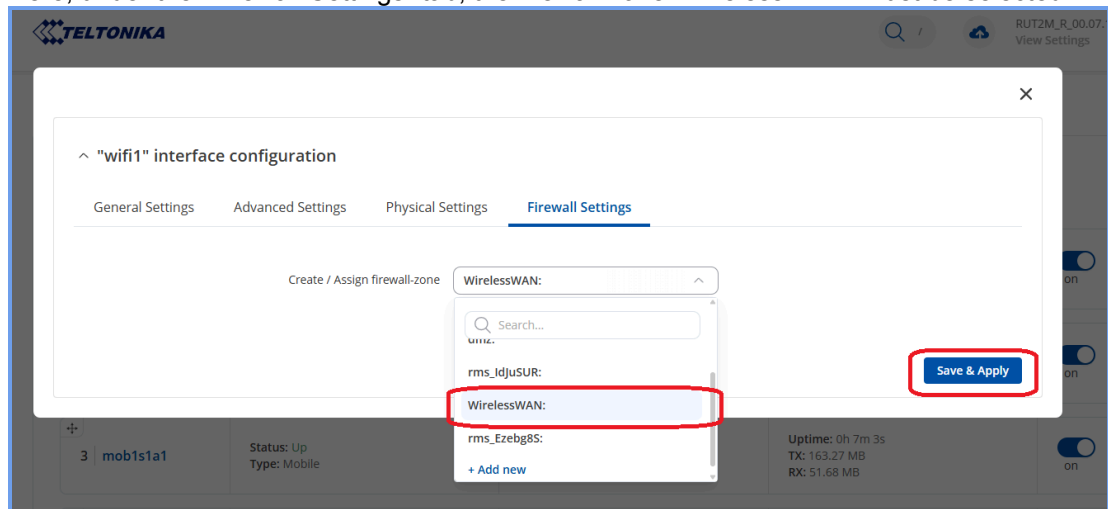

TELTONIKA

RUT2M_R_00.071
View Settings

^ "wifi1" interface configuration

General Settings Advanced Settings Physical Settings **Firewall Settings**

Create / Assign firewall-zone

WirelessWAN:

Search...

rms_IdJuSUR:

WirelessWAN:

rms_Ezebg8S:

+ Add new

Save & Apply

3 | mob1s1a1 Status: Up Type: Mobile Uptime: 0h 7m 3s TX: 163.27 MB RX: 51.68 MB

- Then you can confirm with “Save & Apply”.

Accessing the AirTracker interface via the existing network:

- Navigate to “Status --> Overview” and scroll to the relevant WiFi, e.g. TEKA / WIFI1. This is where you can, among other things, see the IP address assigned to the AirTracker.

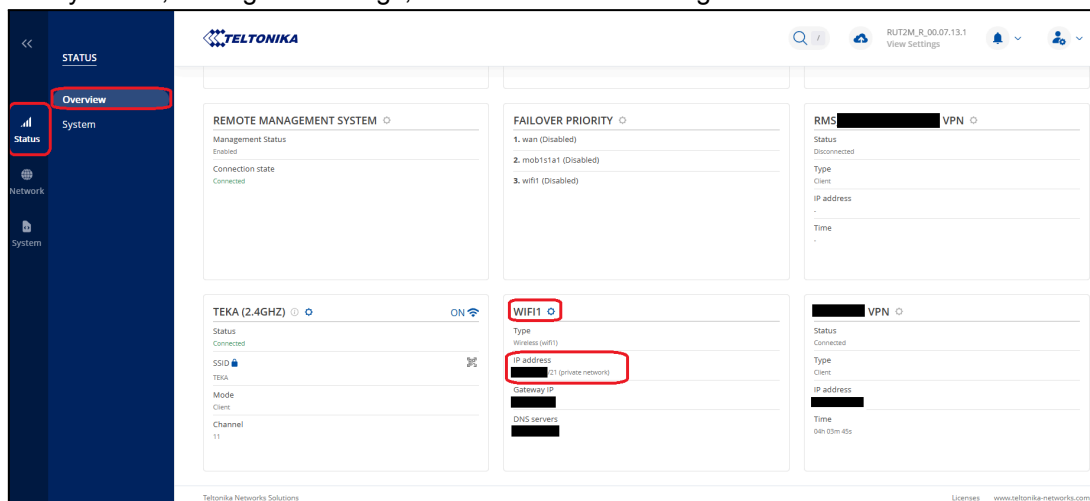

- You can disconnect the Ethernet connection from your end device to the AirTracker. Make sure that your end device is connected to the correct network after the changes to the settings.
- With the allocated IP address plus the port “5800”, the AirTracker interface can now be opened in any browser. For example: **192.168.188.11:5800**
The password prompt appears in the browser. The password is: **24364**. Then the user interface of the AirTracker appears.

14.4.2. Integrating the AirTracker using a static IP address (wireless)

 **IMPORTANT** : When using this connection type with the AirTracker, the IP address settings **must** be set to the default values, see chapter 7.4. “Settings menu → Settings 4”.

Connecting to the integrated router of the AirTracker:

- Connect your end device to the RJ45 port (see chapter 2.1) of the AirTracker (see chapter 14.1).
- The LAN port of the AirTracker’s router has the following IP address by default: **10.19.95.1**
Temporarily set your end device to the same address range to have access to the router of the AirTracker.
- The following IP address can then be accessed in the browser: **10.19.95.1**

Logging on to the integrated router of the AirTracker:

- The login page for the router opens in the browser. Enter the following credentials:
Username: **user** / Password: **Router24364**

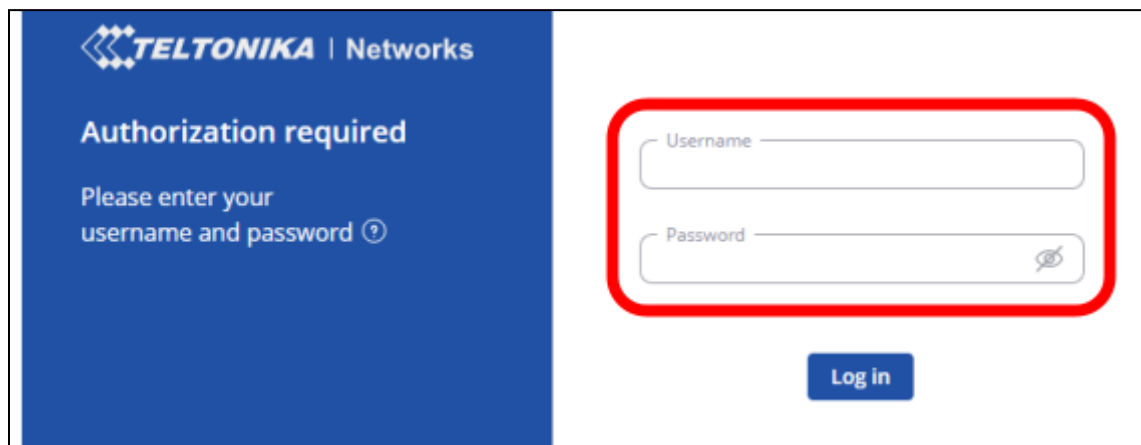

The image shows the login page of the Teltonika Networks router. On the left, a blue sidebar contains the Teltonika logo and the text "Authorization required" and "Please enter your username and password". On the right, there are two input fields: "Username" and "Password". The "Password" field has an eye icon to toggle visibility. A red rectangle highlights both input fields. Below the fields is a blue "Log in" button.

- After logging in, go to "Network → Wireless". In this menu, you can search for the existing WiFi network. To do this, press the "Scan 2.4 GHz" button.

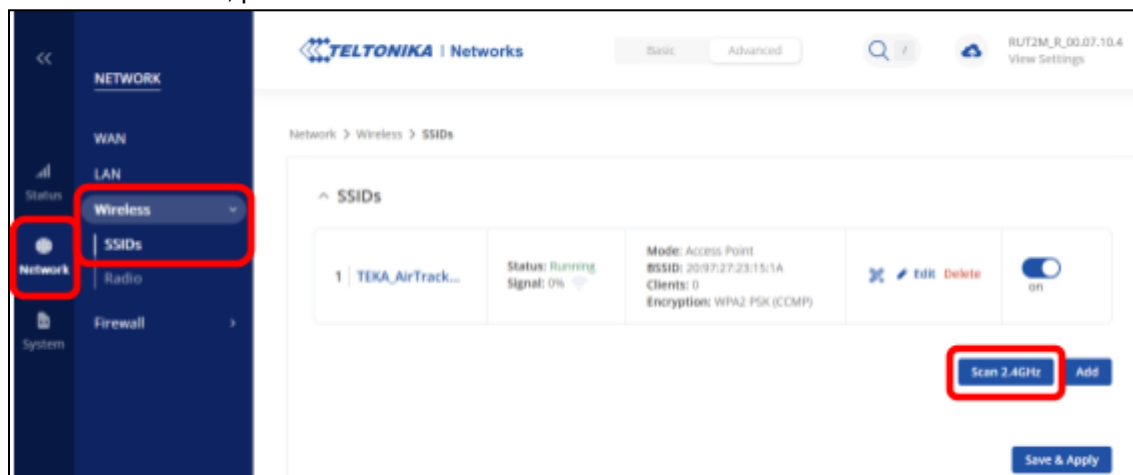

- A list of accessible WiFi networks will open. Select the desired network. Confirm the selection with "join network".
Then enter the WPA key of the target network and confirm it.



You can only connect to one additional external WiFi network; otherwise, an error message appears when you try to add the network.

- A menu window will open with settings for the target network.
Check the desired settings in the "General Setup" tab.

- In the “Additional Settings”, enable the function “Enable fast roaming: ON”. After enabling the function, an additional tab “Fast Roaming” will appear. The basic settings can be used here.

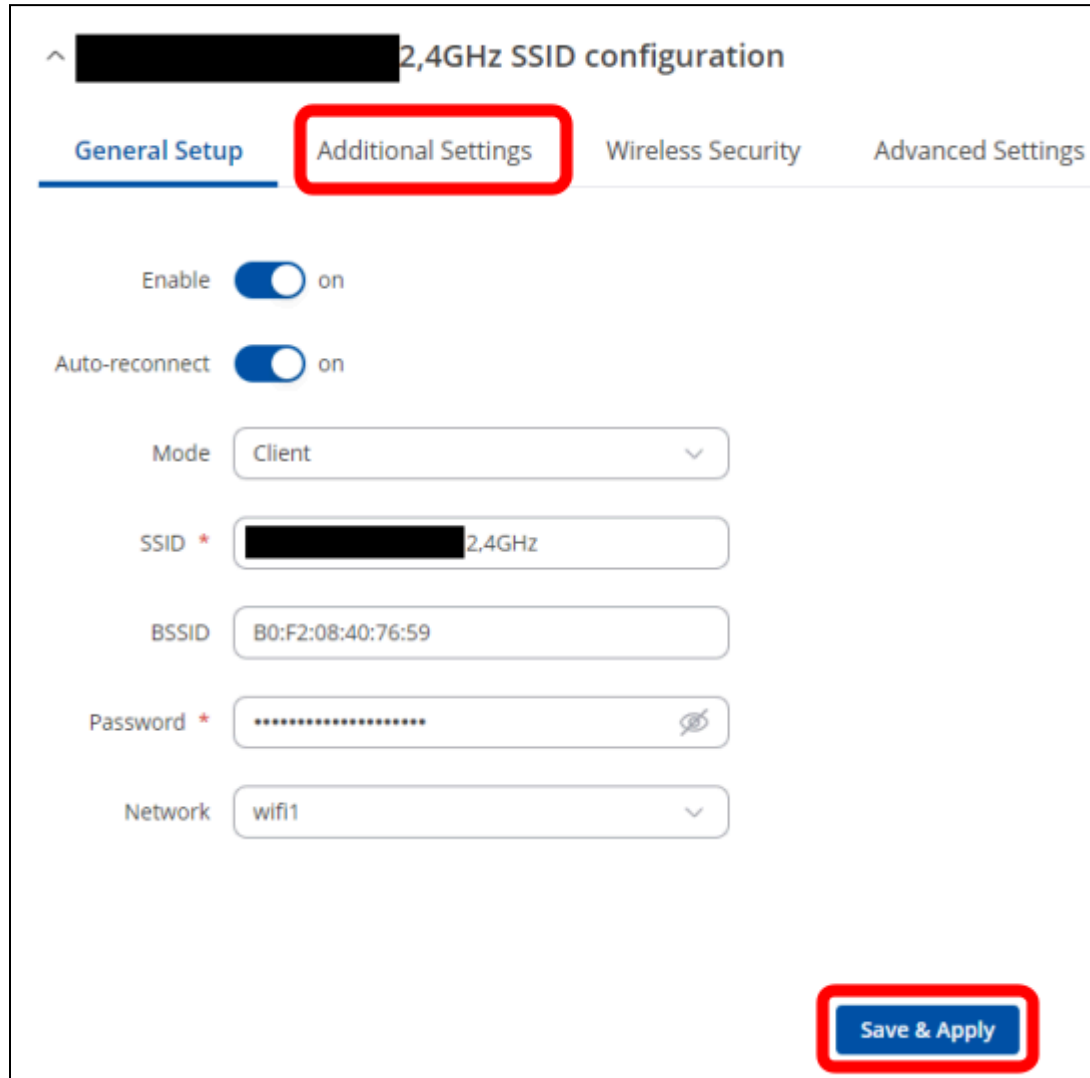

^ [REDACTED] 2,4GHz SSID configuration

General Setup **Additional Settings** Wireless Security Advanced Settings

Enable on

Auto-reconnect on

Mode Client

SSID * [REDACTED] 2,4GHz

BSSID B0:F2:08:40:76:59

Password * [REDACTED]

Network wifi1

Save & Apply

- Then you can confirm with “Save & Apply”.

- After that, the settings for “Interfaces: wifi1” will open. Select “Static” in the drop-down menu under “Protocol”.

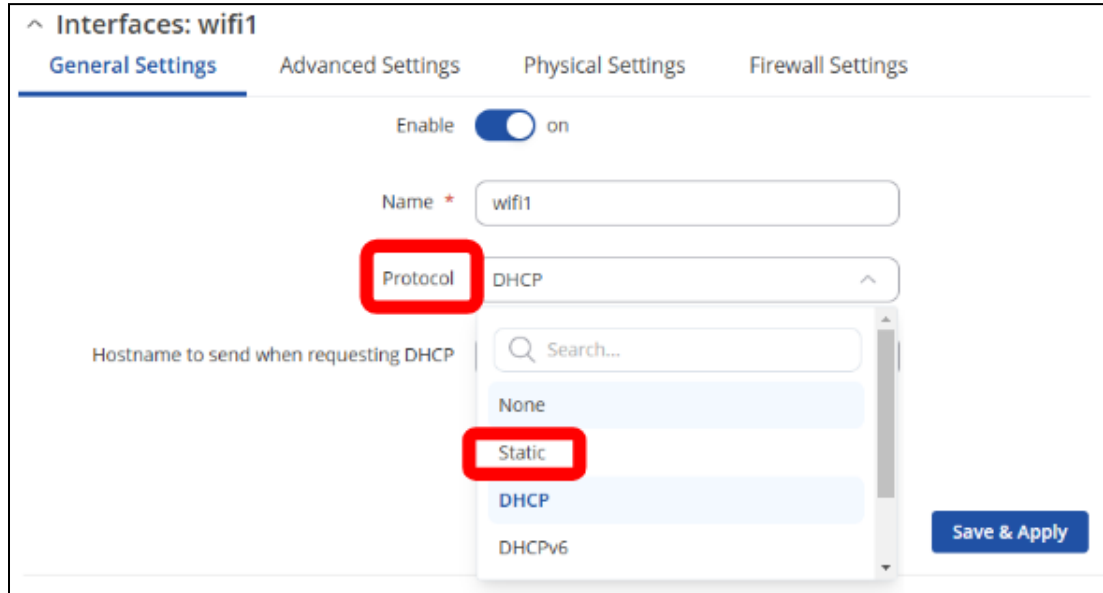

^ Interfaces: wifi1

General Settings | Advanced Settings | Physical Settings | Firewall Settings

Enable on

Name * wifi1

Protocol DHCP

Hostname to send when requesting DHCP

Search...

None

Static

DHCP

DHCPv6

Save & Apply

- After that, further input windows will open in which the desired IP address for the AirTracker is entered.

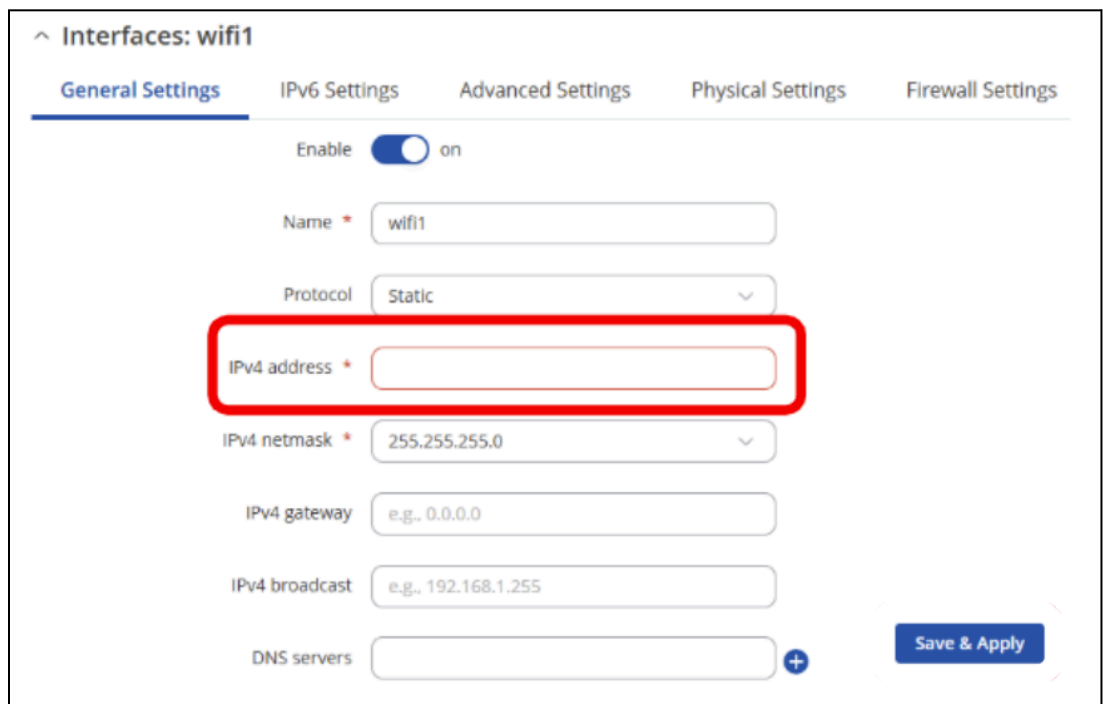

^ Interfaces: wifi1

General Settings | IPv4 Settings | Advanced Settings | Physical Settings | Firewall Settings

Enable on

Name * wifi1

Protocol Static

IPv4 address *

IPv4 netmask * 255.255.255.0

IPv4 gateway e.g., 0.0.0.0

IPv4 broadcast e.g., 192.168.1.255

DNS servers +

Save & Apply

- Under the “Firewall Settings” tab, the firewall zone “WirelessWAN” must be selected.

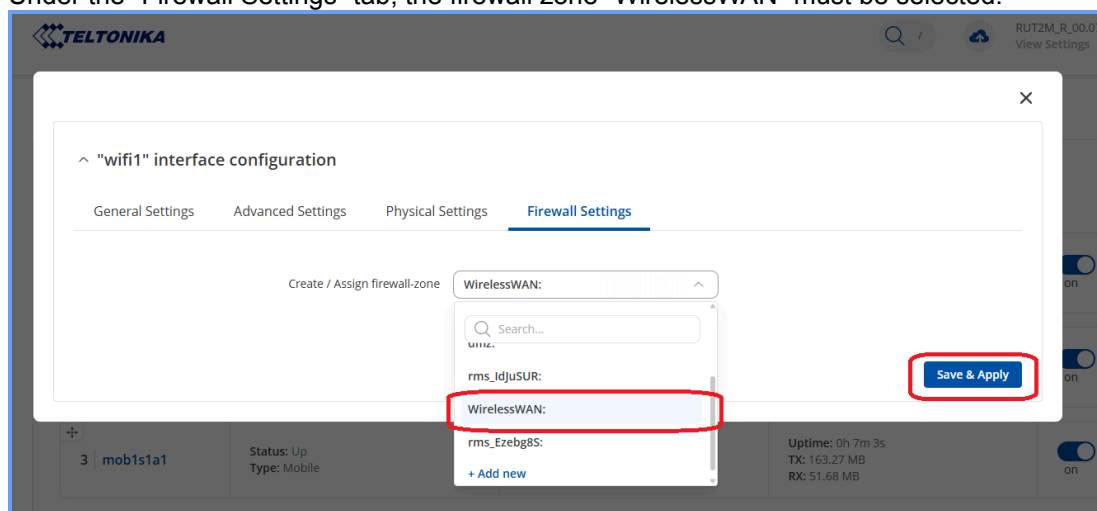

- Then you can confirm with “Save & Apply”.
- After these steps, the AirTracker is integrated in the desired network as a participant.

Accessing the AirTracker interface via the existing network:

- Navigate to “Status --> Overview” and scroll to the relevant WiFi, e.g. TEKA / WIFI1. This is where you can, among other things, see the IP address assigned to the AirTracker

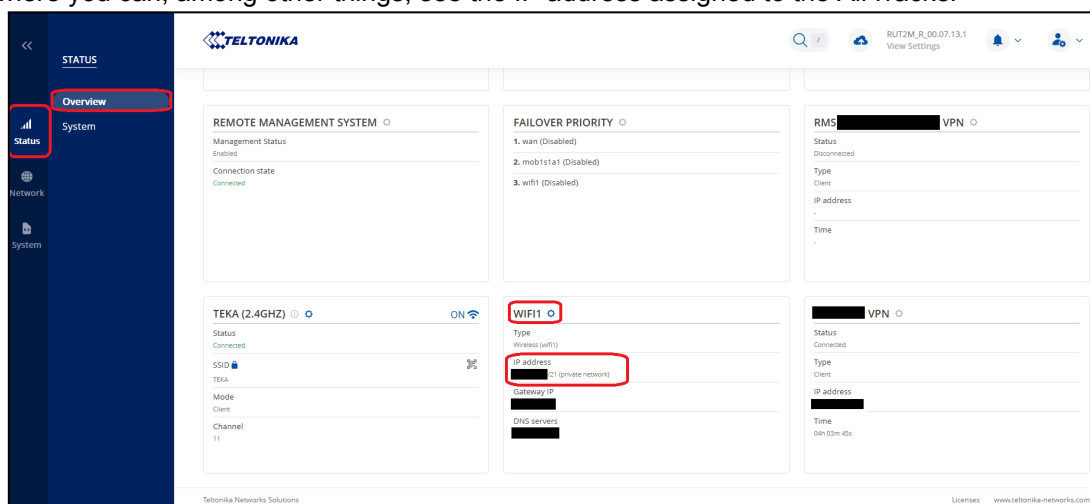

- You can disconnect the Ethernet connection from your end device to the AirTracker. Make sure that your end device is connected to the correct network after the changes to the settings.
- With the static IP address plus the port “5800”, the AirTracker interface can now be opened in any browser. For example: **192.168.188.11:5800**
The password prompt appears in the browser. The password is: **24364**. Then the user interface of the AirTracker appears.

14.5. Integrating the AirTracker into an existing LAN (wired)

The following section describes the wired integration into an existing LAN (Local Area Network) by connecting the AirTracker via Ethernet cable to the RJ45 port (see chapter 2.1).

14.5.1. Integrating the AirTracker via DHCP IP address allocation (wired)

We recommend a WiFi connection for DHCP operation of the AirTracker. The AirTracker is not designed for wired DHCP operation.

If wired operation of the AirTracker is necessary in a DHCP network, we recommend assigning a static IP to the AirTracker (AirTracker interface → Settings 4, see following section) that is within the appropriate address range but outside the automatically assigned DHCP range.

For further information on network configuration, please contact your system administrator or router manufacturer. In addition, the following settings are to be made in the AirTracker router:

Connecting to the integrated router of the AirTracker:

- Connect your end device to the RJ45 port (see chapter 2.1) of the AirTracker (see chapter 14.1).
- The LAN port of the AirTracker's router has the following IP address by default: **10.19.95.1**
Temporarily set your end device to the same address range to have access to the router of the AirTracker.
- The following IP address can then be accessed in the browser: **10.19.95.1**

Logging on to the integrated router of the AirTracker:

- The login page for the router opens in the browser. Enter the following credentials:
Username: **user** / Password: **Router24364**

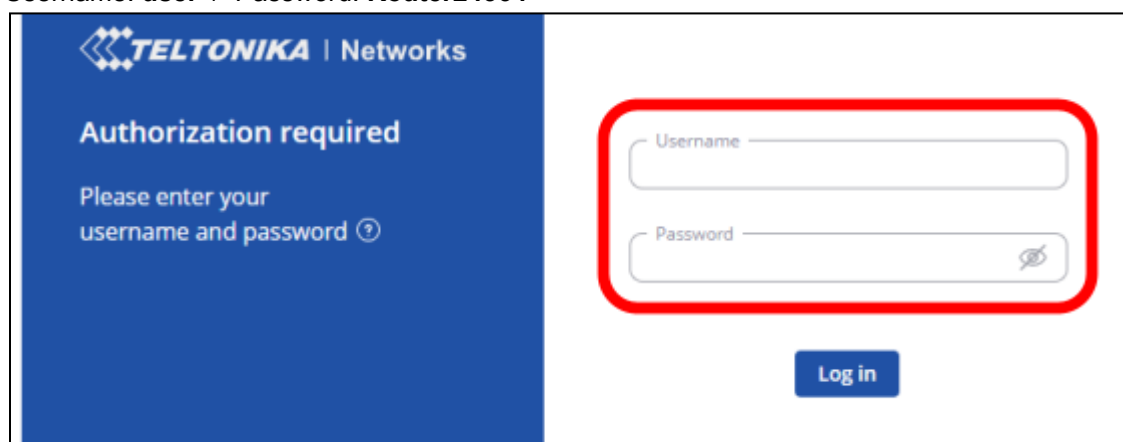

Customizing the LAN port settings of the AirTracker:

- Go to “ Network → LAN”.
- Then select “Edit”.

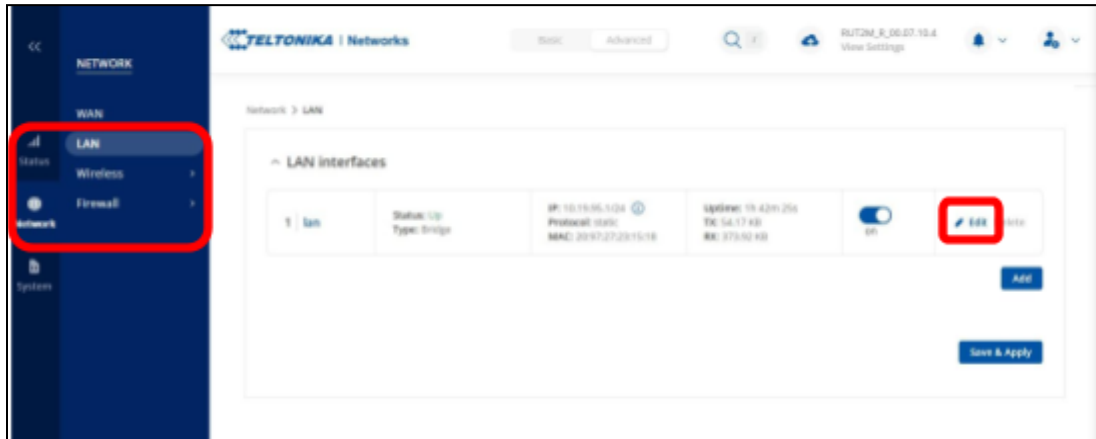

- In the menu that opens, disable the settings “Enable DHCPv4 “ and “ Enable DHCPv6”.
- Confirm with “Save & Apply”.

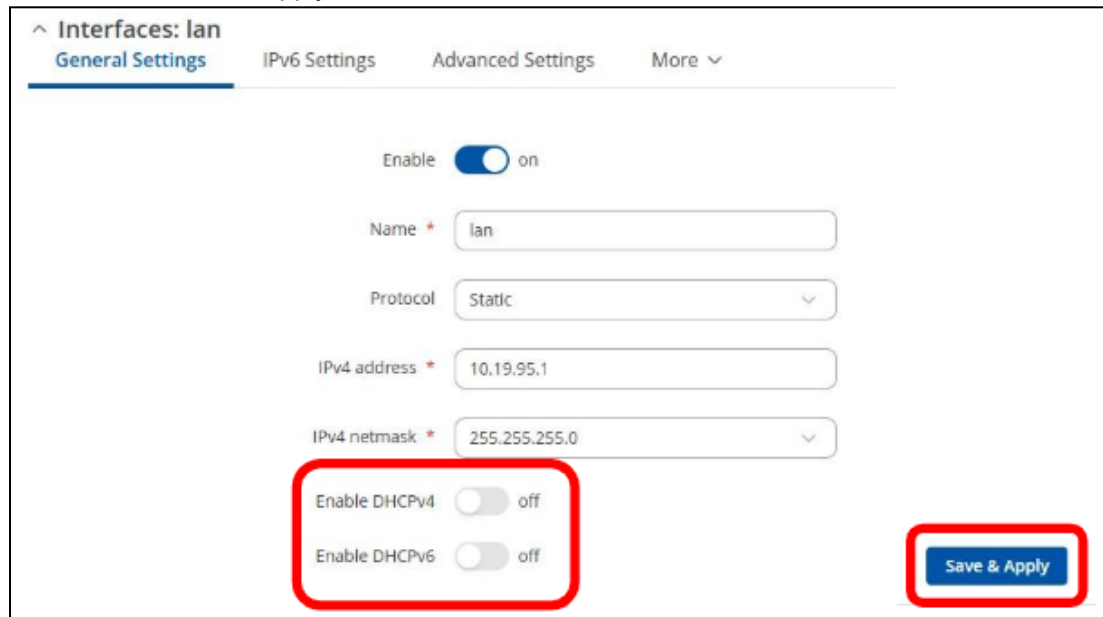

- You can use the AirTracker with a static IP in the DHCP network.
- Make sure that your end device and the AirTracker are connected to the correct network.
- With the static IP address plus the port “5800”, the AirTracker interface can now be opened in any browser. For example: **10.19.95.80:5800**
The password prompt appears in the browser. The password is: **24364**. Then the user interface of the AirTracker appears.

14.5.2. Integrating the AirTracker using a static IP address (wired)

- To establish a connection with static IP address, you can use the preset default values or adjust them to your application case in the Settings 4 menu. It is usually not necessary to change settings in the AirTracker's internal router.

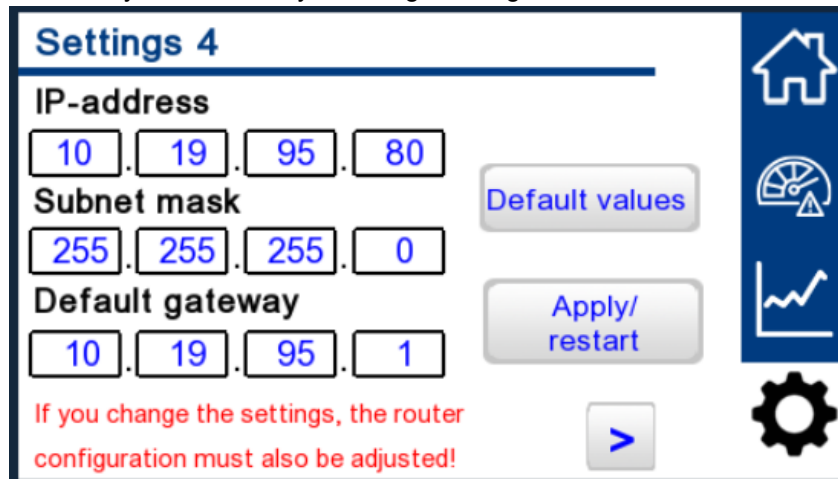

Settings 4

IP-address
10 . 19 . 95 . 80

Subnet mask
255 . 255 . 255 . 0

Default gateway
10 . 19 . 95 . 1

If you change the settings, the router configuration must also be adjusted!

Default values

Apply/restart

>

- Make sure that your end device and the AirTracker are connected to the correct network.
- With the static IP address plus the port "5800", the AirTracker interface can now be opened in any browser. For example: **10.19.95.80:5800**
The password prompt appears in the browser. The password is: **24364**. Then the user interface of the AirTracker appears.

15. Defining the router's transmission properties



This chapter only applies to AirTrackers operated outside of Germany.

This chapter explains how to change the transmission properties, such as the transmission power and the frequency band. These are specified by national laws and vary depending on the location of the AirTracker. The AirTracker is set by default to operate in Germany.

Connecting to the integrated router of the AirTracker:

- Connect your end device to the RJ45 port (see chapter 2.1) of the AirTracker (see chapter 14.1).
- The LAN port of the AirTracker's router has the following IP address by default: **10.19.95.1**
Temporarily set your end device to the same address range to have access to the router of the AirTracker.
- The following IP address can then be accessed in the browser: **10.19.95.1**

Logging on to the integrated router of the AirTracker:

- The login page for the router opens in the browser. Enter the following credentials:
Username: **user** / Password: **Router24364**

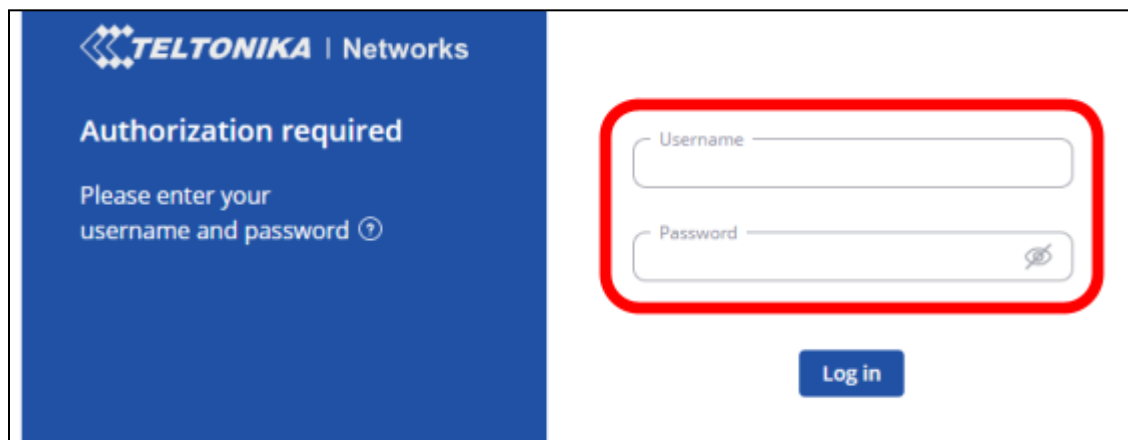

TELTONIKA | Networks

Authorization required

Please enter your username and password ⓘ

Username

Password ⓘ

Log in

- Go to “Network” --> “Wireless” → “Radio”.

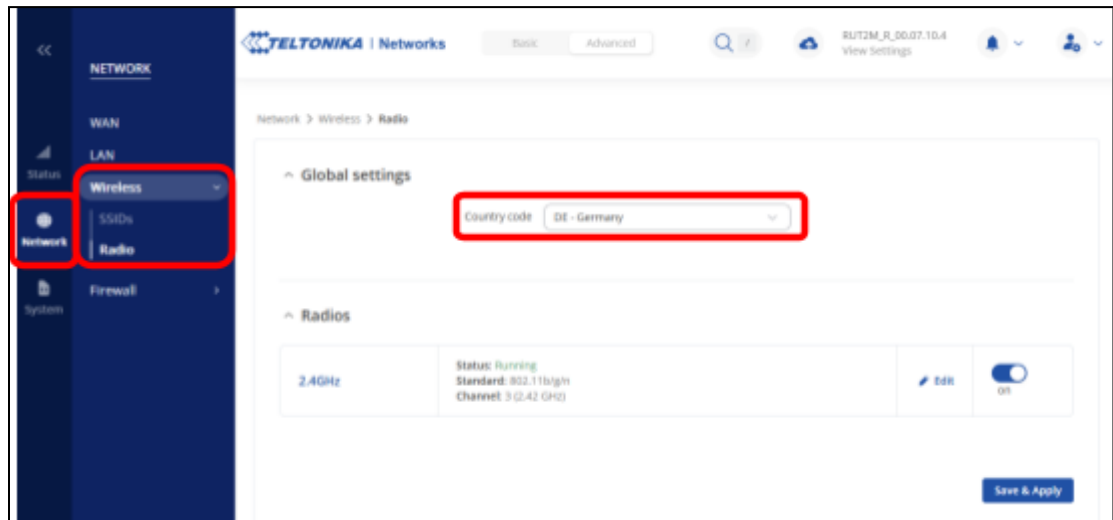

- The country in which the AirTracker is operated can be selected under the item “Country code”.
- Confirm with “Save & Apply”.

16. Resetting the AirTracker router



This chapter explains how to reset the internal router to TEKA factory settings. All settings made by the user will be lost.

Connecting to the integrated router of the AirTracker:

- Connect your end device to the RJ45 port (see chapter 2.1) of the AirTracker (see chapter 14.1).
- The LAN port of the AirTracker's router has the following IP address by default: **10.19.95.1**
Temporarily set your end device to the same address range to have access to the router of the AirTracker.
- The following IP address can then be accessed in the browser: **10.19.95.1**

Logging on to the integrated router of the AirTracker:

- The login page for the router opens in the browser. Enter the following credentials:
Username: **user** / Password: **Router24364**

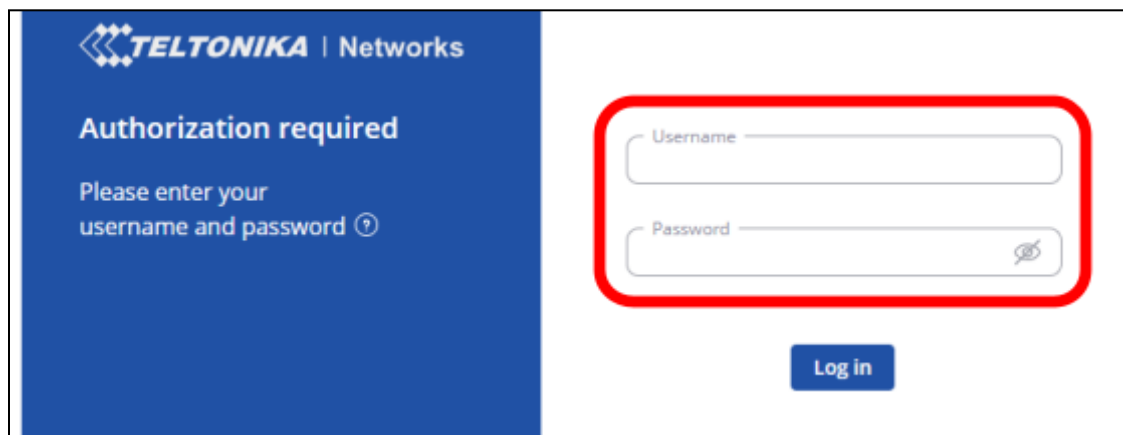

- Go to "System" --> "Maintenance" → "Reset Settings".

- **IMPORTANT:** under “Reset settings”, select the item “User’s default configuration”.

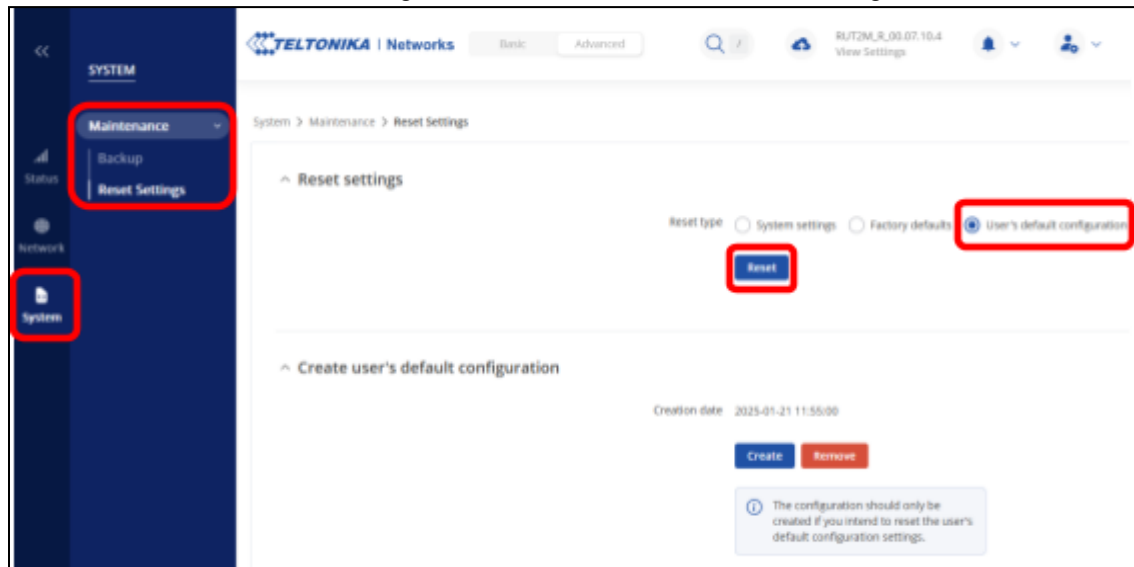

- The process is started by pressing the “Reset” button. The settings will be reset and the router will restart. This can take a few minutes. Then the router is in its default state.

 The backup function is used to create and restore configurations. It is recommended to use this function only in consultation with the TEKA service department.